

## U-Nuts

Tapped Barrel

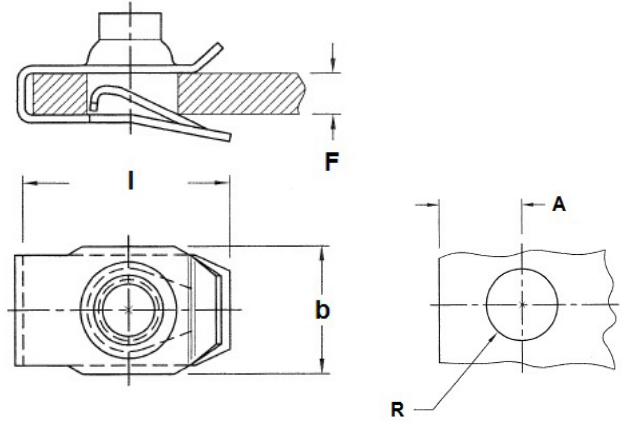

### APPLICATION INFORMATION

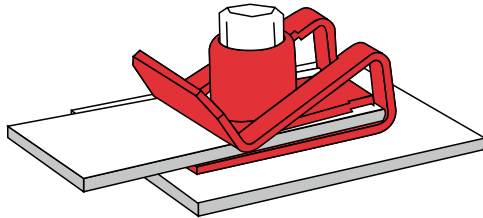

- Used to provide simple, rapid attachment of mating panels
- Parts self-retain in screw-receiving position
- Preferred alternative for machine screws
- The barrel comes in prevailing torque and free-spinning options
- The nut is slid onto the panel edge and over the panel hole
- Self-retention feature improves assembly time and eliminates costly welding and clinching costs
- Corrects misalignment in panel mounting holes
- Part does not turn as the screw is driven and will not freeze on screw threads
- Serviceable - parts disassemble easily and reliably
- Can be used wherever a screw or bolt is used and in place of clinch nuts and weld nuts
- Easy to assemble, requiring no special tools
- The tapped barrel strength equals that of the screw



VIDEO ON U-NUTS

VIEW HERE



On Panel Edges

## U-Nuts Tapped Barrel

### Imperial

Part Number	Legacy Part Number	Thread Specification	Panel Thickness (F)	Throat Distance (A)	Hole Diameter (R)	Width (b)	Length (l)	Torque
138337	LUGS832006	8-32	0.020 - 0.079	0.383	0.280 - 0.280	0.492	0.681	5
138347	LUGZ103239	10-32	0.070 - 0.100	0.270	0.260 - 0.260	0.510	0.600	5
138332	LUGS142059	1/4-20	0.025 - 0.150	0.450	0.390 - 0.390	0.560	0.920	5
138334	LUGS561863	5/16-18	0.025 - 0.150	0.500	0.437 - 0.437	0.670	0.980	5
138333	LUGS381683	3/8-16	0.050 - 0.200	0.660	0.562 - 0.562	0.930	1.290	5

### Metric

Part Number	Legacy Part Number	Thread Specification	Panel Thickness (F)	Throat Distance (A)	Hole Diameter (R)	Width (b)	Length (l)	Torque
135211	D99390-M42141	ST4.2 (8-18)	2.00 - 3.00	8.60	7.93 - 7.93	12.50	16.90	6
138056	D99389-M42141	ST4.2 (8-18)	0.50 - 2.00	9.10	7.93 - 7.93	12.50	17.30	6
138280	LPGS420018	ST4.2 (8-18)	0.65 - 3.80	14.00	7.55 - 7.55	12.50	22.00	6
138322	LUGS060023	M6x1.0	0.80 - 4.00	12.00	10.30 - 10.30	14.22	23.37	5
138268	LPGS060023	M6x1.0	0.80 - 4.00	12.00	10.30 - 10.30	14.22	23.37	6
135210	LUGZ002112	M6x1.0	0.80 - 3.81	12.00	10.30 - 10.30	14.22	23.37	5
138282	LPGZ002112	M6x1.0	0.80 - 3.81	12.00	10.30 - 10.30	14.22	23.37	6
135206	LUGZ002241	M6x1.0	0.80 - 3.81	12.00	10.30 - 10.30	14.22	23.37	5
135202	LPGZ002241	M6x1.0	0.80 - 3.81	12.00	10.30 - 10.30	14.22	23.37	6
138326	LUGS061512	M6x1.0	0.80 - 4.00	11.00	7.93 - 7.93	15.00	24.00	5
138324	LUGS060030	M6x1.0	1.00 - 2.50	19.75	10.30 - 10.30	14.50	29.50	5
138328	LUGS080025	M8x1.25	0.80 - 4.00	13.00	11.70 - 11.70	17.02	24.89	5
138272	LPGS080025	M8x1.25	0.80 - 4.00	13.00	11.70 - 11.70	17.02	24.89	6
138289	LPGZ080025	M8x1.25	0.80 - 4.00	13.00	11.70 - 11.70	17.02	24.89	6
138330	LUGS085725	M8x1.25	1.50 - 5.50	13.00	11.70 - 11.70	17.02	24.89	5
135220	LPGS085725	M8x1.25	1.50 - 5.50	13.00	11.70 - 11.70	17.02	24.89	6
138329	LUGS080031	M8x1.25	1.50 - 5.50	20.00	11.70 - 11.70	17.00	31.50	5
138273	LPGS080031	M8x1.25	1.50 - 5.50	20.00	11.70 - 11.70	17.00	31.50	6
138331	LUGS100033	M10x1.5	1.50 - 5.50	17.50	15.00 - 15.00	17.50	32.50	5
138276	LPGS100033	M10x1.5	1.50 - 5.50	17.00	12.00 - 12.00	24.00	33.50	6

Most parts manufactured in spring steel  
5: Free Spinning Barrel  
6: Prevailing Torque Barrel