

ORIGINAL INSTRUCTIONS

GB912

HYDRAULIC POWERUNIT

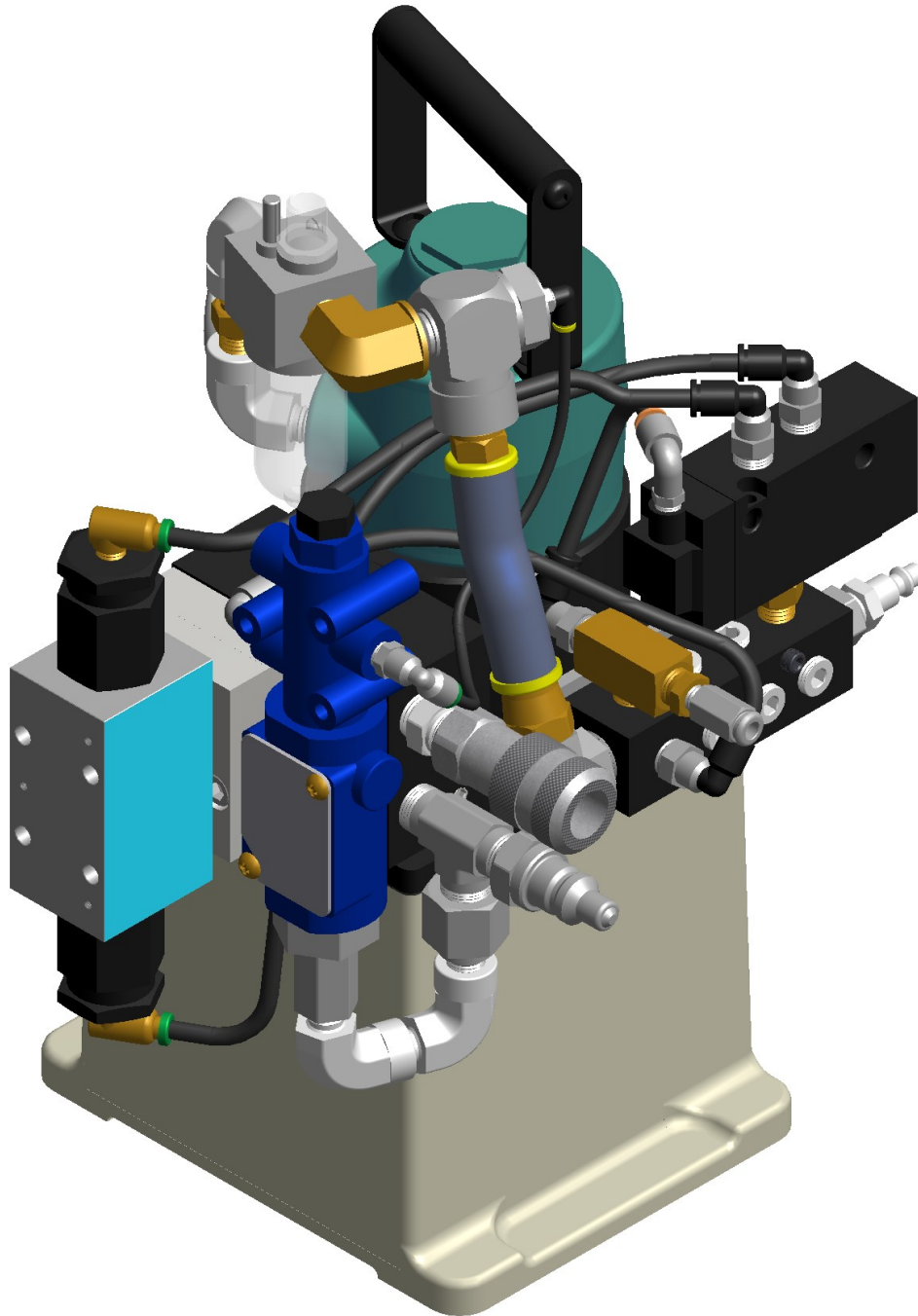

GAGE BILT TOOLS ARE AVAILABLE WORLDWIDE
E-MAIL US FOR A DISTRIBUTOR NEAR YOU.

GAGE BILT
 MADE in USA

44766 Centre Court Clinton Twp. MI 48038 USA
Ph: +1 (586) 226-1500 Fax: +1 (586) 226-1505
solutions@gagebilt.com / www.gagebilt.com

DESCRIPTION



⚠ WARNING: Any other use is forbidden.

The GB912 Powerunit is a portable, air operated hydraulic power source designed to operate Gage Bilt hydraulic installation equipment. It is also compatible with HUCK® hydraulic installation equipment.

The GB912 Powerunit operates on 90 - 100 psi. (6.2-6.9 bar), using 40 cfm @ 100 psi. (6.9 bar). **The minimum hose recommended is ½" ID.**

Pages 15 –17 shows construction features of the GB912 Powerunit and identifies main components. Hydraulic pressure is developed by a two-stage, gear piston hydraulic pump driven by a 1-1/2 hp motor. Pump output is directed to either the PULL or RETURN pressure ports of the installation equipment by a four-way directional valve. The directional valve is controlled from the installation equipment by an air actuator.

For the protection of the equipment and operator, an internal relief valve is pre-set at the factory. An external relief valve controls the PULL pressure and can be adjusted for pressures between 1,000 psi. –10,000 psi. which operates on 40 cfm of air at 100 psi. (6.9 bar). A pressure switch controls the RETURN pressure and automatically turns off the GB912 Powerunit. When the air actuator is released, the installation cycle is finished. As shipped by the factory, the external relief valve Pull pressure is set at 6,000 psi (41,370 kPa) & Return pressure 2,400 psi (16,547 kPa).

The pump is equipped with a handle to ease the transferring of the GB912 Powerunit to various sites. The GB912 Powerunit weighs approximately 46.5 lbs. (21.1 Kg) when filled with hydraulic oil.

Hydraulic quick disconnect couplers are supplied for connecting the tool hoses from the installation equipment.

ENVIRONMENTAL USE

⚠ WARNING: Do not operate in an explosive atmosphere.

The GB912 can be operated between 0°F — 118°F (-17.8°C / 47.8°C)

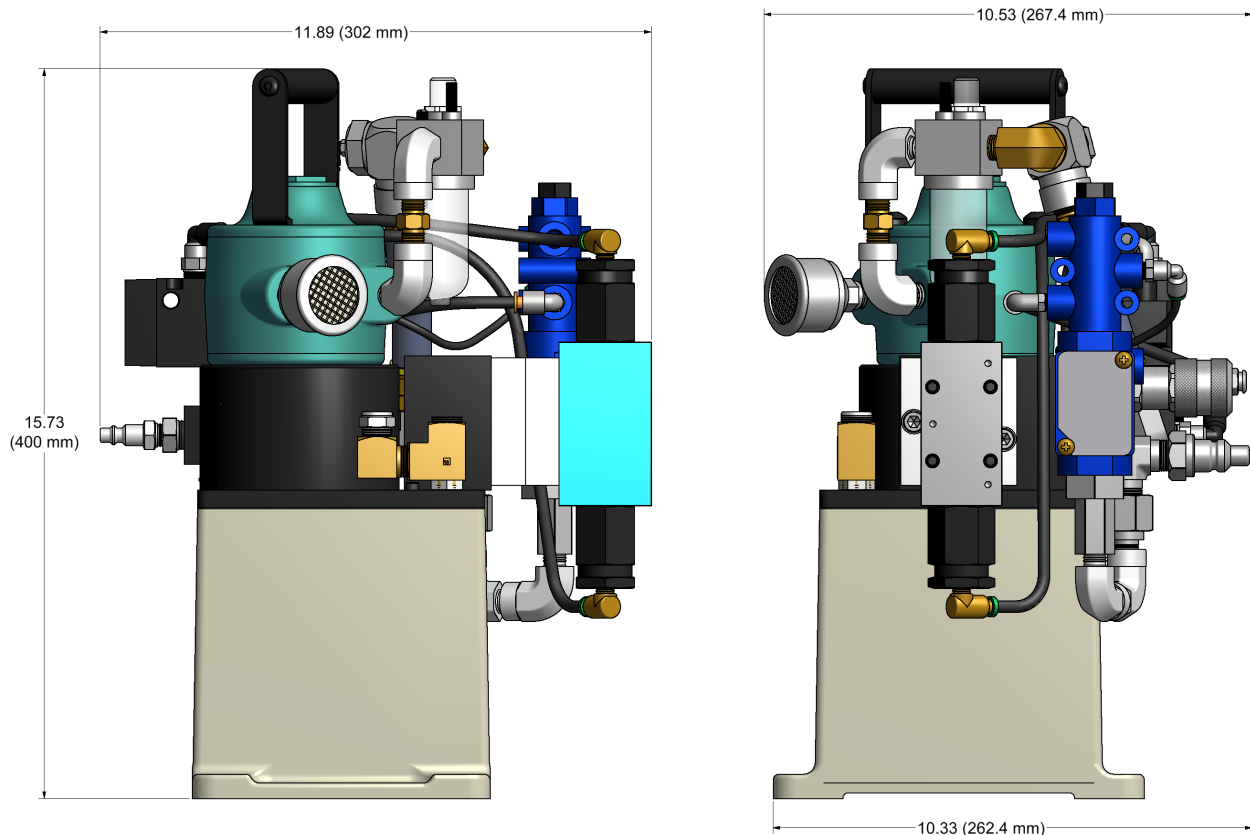

SPECIFICATIONS

Hand Held Weight	- 46.5 lbs. (21.1 kg)
Air pressure req'd	- 90-100 p.s.i. (6.2-6.9 bar)
Air consumption	- 40 CFM @ 100 PSI. (6.9 bar)
Hydraulic oil	- AW-32, or equivalent.
Output Pressure	- Adjustable to 10,000 psi. (68,947.6 kPa) (shipped with Pull pressure 6,000 psi. (41,370 kPa) (shipped with RETURN pressure 2,400 psi. (16,547 kPa).
Noise level	- 81.5 dB(A)
Vibration	- Tested– No hazards found

DESCRIPTION OF FUNCTIONS

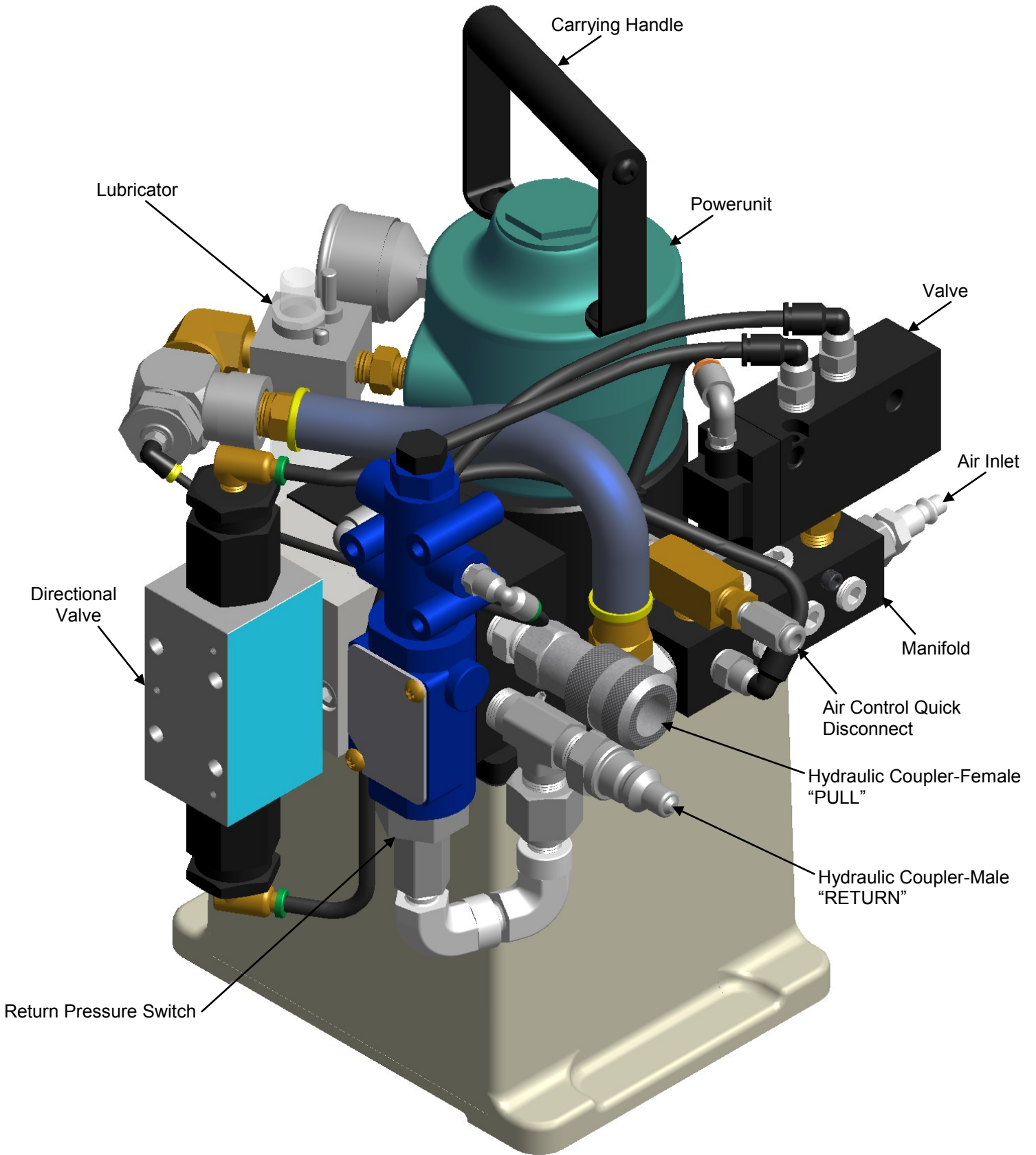



TERMS AND SYMBOLS



- Product complies with requirements



- Hearing protection and eye protection



- Read manual prior to using equipment



- Wear safety boots



WARNINGS - Must be understood to avoid severe personal injury.



CAUTIONS - show conditions that will damage equipment and/or structure.

Notes - are reminders of required procedures.

OPERATING HAZARDS:

1. Use of tool can expose the operator's hands to hazards, including crushing, impacts, cuts, abrasions and heat. Wear suitable gloves to protect hands.
2. Operators and maintenance personnel shall be physically able to handle the bulk, weight and power of the tool.
3. Hold the tool correctly; be ready to counteract normal or sudden movements and have both hands available.
4. Maintain a balanced body position and secure footing.
5. Release the start-and-stop device in the case of interruption of energy supply.
6. Use only lubricants recommended by the manufacturer.
7. Avoid unsuitable postures as it is likely for these positions not to allow counteracting of normal or unexpected movement of the tool.
8. If the tool is fixed to a suspension device, make sure that fixation is secure.
9. Beware of the risk of crushing or pinching if nose equipment is not fitted.
10. Due to the tool weight, it is recommended safety shoes be worn during operation.
11. It is recommended tool be operated not more than 50 out of every 60 minutes, where prolonged use is expected.

REPETITIVE MOTIONS HAZARDS:

1. When using the tool, the operator can experience discomfort in the hands, arms, shoulders, neck or other parts of the body.
2. While using the tool, the operator should adopt a comfortable posture while maintaining a secure footing and avoiding awkward or off balanced postures. The operator should change posture during extended tasks; this can help avoid discomfort and fatigue.
3. If the operator experiences symptoms such as persistent or recurring discomfort, pain, throbbing, aching, tingling, numbness, burning sensations or stiffness, these warning signs should not be ignored. The operator should tell the employer and consult a qualified health professional.

ACCESSORY HAZARDS:

1. Disconnect tool from energy supply before changing the nose assembly or accessory.
2. Use only sizes and types of accessories recommended by the manufacturer. Do not use other types or sizes of accessories.

WORKPLACE HAZARDS:

1. Slips, trips and falls are major causes of workplace injury. Be aware of slippery surfaces caused by use of tool and also of trip hazards caused by the air line or hydraulic hose.
2. Proceed with care in unfamiliar surroundings. There could be hidden hazards, such as electricity or other utility lines.
3. The tool is not intended for use in potentially explosive atmospheres and is not insulated against contact with electrical power.
4. Ensure that there are no electrical cables, gas pipes, etc., which can cause a hazard if damaged by the tool.

NOISE HAZARDS:

1. Exposure to high noise levels can cause permanent, disabling hearing loss and other problems, such as tinnitus (ringing, buzzing, whistling or humming in the ears). Therefore, risk assessment and the implementation of appropriate controls for these hazards are essential.
2. Appropriate controls to reduce the risk may include actions such as damping materials to prevent workpieces from "ringing".
3. Use hearing protection in accordance with employer's instructions and as required by occupational health and safety regulations.
4. Operate and maintain the assembly power tool for non-threaded mechanical fasteners as recommended in the instruction handbook, to prevent an unnecessary increase in the noise level.
5. Select, maintain and replace the consumable/inserted tool as recommended in the instruction handbook, to prevent an unnecessary increase in noise.
6. If the power tool has a silencer, always ensure that it is in place and in good working order when the power tool is being operated.

VIBRATION HAZARDS:

1. Exposure to vibration can cause disabling damage to the nerves and blood supply of the hands and arms.
2. Wear warm clothing when working in cold conditions and keep your hands warm and dry.
3. If you experience numbness, tingling, pain or whitening of the skin in your fingers or hands, stop using the assembly power tool for non-threaded mechanical fasteners, tell your employer and consult a physician.
4. Support the weight of the tool in a stand, tensioner or balancer, because a lighter grip can then be used to support the tool.

GENERAL SAFETY RULES:

1. For multiple hazards, read and understand the safety instructions before installing, operating, repairing, maintaining, changing accessories on, or working near the assembly power tool for non-threaded mechanical fasteners.
2. Only qualified and trained operators should install, adjust or use the assembly power tool for non threaded mechanical fasteners.
3. Do not modify this assembly power tool for non-threaded mechanical fasteners. Modifications can reduce effectiveness of safety measures and increase the risks to the operator.
4. Do not discard safety instructions; give them to the operator.
5. Do not use assembly power tool for non-threaded mechanical fasteners if it has been damaged.
6. Tools shall be inspected periodically to verify all ratings and markings required are legible. The employer/user shall contact the manufacturer to obtain replacement marking labels when necessary.
7. Air under pressure can cause severe injury.
8. Always shut off air supply, drain hose of air pressure and disconnect tool from air supply when not in use, before changing accessories or when making repairs.
9. Never direct air at yourself or anyone else.
10. Whipping hoses can cause severe injury. Always check for damage or loose hoses and fittings.
11. Cold air shall be directed away from hands.
12. Whenever universal twist couplings (claw couplings) are used, lock pins shall be installed and whipcheck safety cables shall be used to safeguard against possible hose-to-tool or hose-to-hose connection failure.
13. Do not exceed the maximum air pressure stated on the tool or manual.
14. Never carry an air tool by the hose.

ADDITIONAL SAFETY RULES FOR PNEUDRAULIC POWER TOOLS:

1. Air under pressure can cause severe injury.
2. Always shut off air supply, drain hose of air pressure and disconnect tool from air supply when not in use, before changing accessories or when making repairs.
3. Never direct air at yourself or anyone else.
4. Whipping hoses can cause severe injury. Always check for damage or loose hoses and fittings.
5. Cold air shall be directed away from hands.
6. Whenever universal twist couplings (claw couplings) are used, lock pins shall be installed and whipcheck safety cables shall be used to safeguard against possible hose-to-tool or hose-to-hose connection failure.
7. Do not exceed the maximum air pressure stated on the tool or manual.
8. Never carry an air tool by the hose.

PROJECTILE HAZARDS:

1. Disconnect the tool from the energy source when changing inserted tools/nose assemblies or accessories.
2. Be aware that failure of the workpiece or accessories, or even the inserted tool/nose assembly itself can generate high-velocity projectiles.
3. Always wear impact resistant eye protection during operation of the tool. The grade of protection required should be assessed for each use.
4. The risk to others should also be assessed at this time.
5. Ensure that the workpiece is securely fixed.
6. Check that the means of protection from ejection of fastener and/or stem is in place and operative (such as the deflector).
7. Forcible ejection of the mandrel from the front of the nose assembly is possible.

PRINCIPLE OF OPERATION



When the actuator lever assy is depressed on the connected tool, the pressurize air inside of the valve (909104) is released thus allowing spring pressure to shift an internal valve that causes the air to be directed to one side of the directional valve (910034). The air shifts the internal components inside of the directional valve (910034) causing the hydraulic oil to be directed through the manifold block and out of the hydraulic coupler-female (585038). This action simultaneously drops the hydraulic pressure inside the return pressure switch (A-1078). This drop in hydraulic pressure opens the air supply line from the return pressure switch (A-1078) to the solenoid stop valve (A-553) causing it to open allowing the main air supply into the pump starting it. The hydraulic oil is then pumped to the front side of the head cylinder assy, causing the piston to move to the rear position. The internal components of the attached nose assembly are also moving with the piston to start the fastener installation.

When the fastener installation is completed, the actuator lever assy is released. Air pressure is then built up inside of the valve (909104) causing the internal valve to shift back. This shift redirects the air to the opposite side of the directional valve (910034) while shifting the internal components back and redirecting the hydraulic oil to the return port in the manifold block. The oil then moves to the rear of the head cylinder assy returning the head piston to its original position and reversing the sequence. When the piston reaches full forward, pressure starts to build. After the return pressure switch (A-1078) senses the set pressure, the internal components shift, shutting off the air supply to the solenoid stop valve (A-553) thus closing off the main air supply stopping the pump.

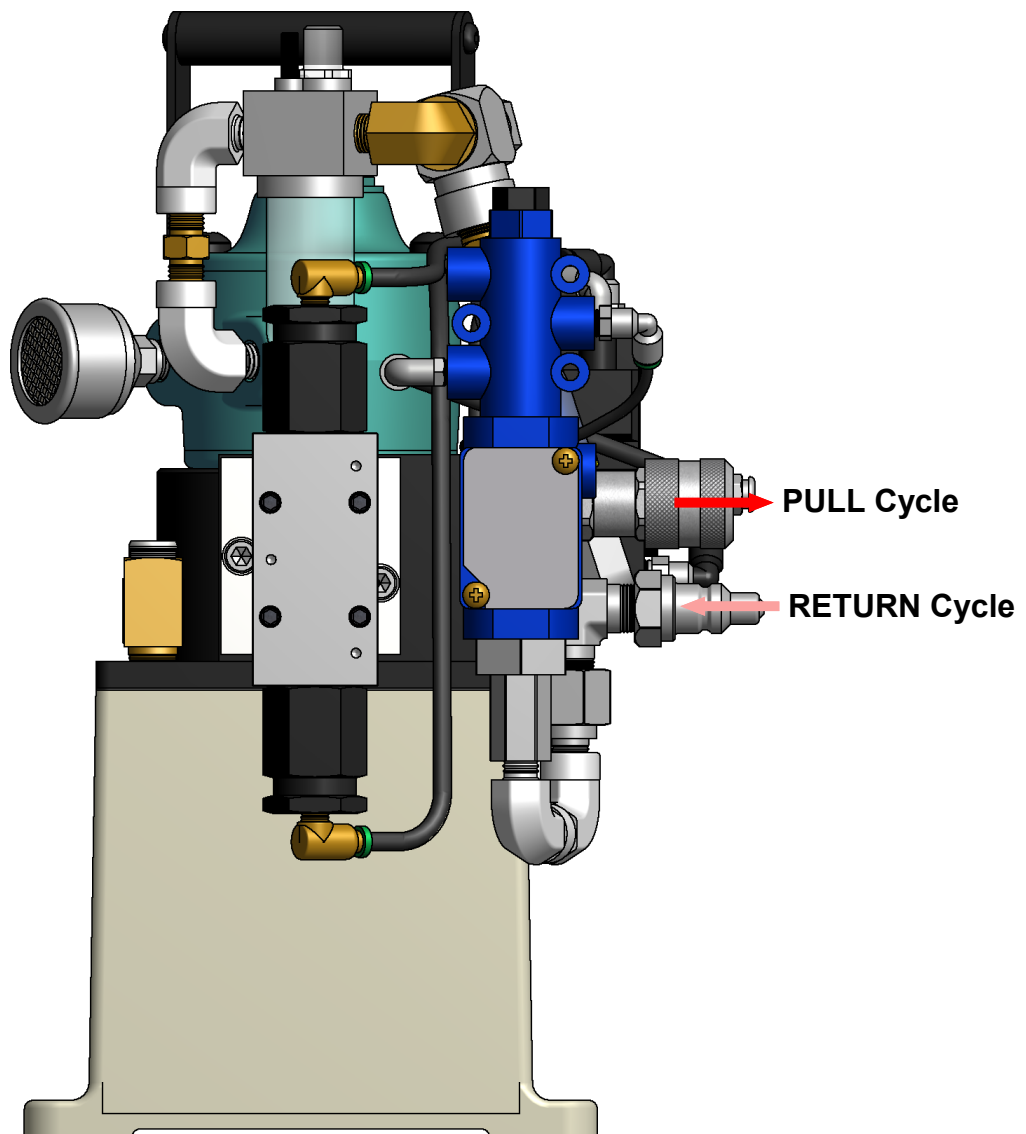



-  Pressurized Oil
-  Return Oil

Image may not reflect actual tool.

HOW TO SET-UP THE GB912



- ⚠ WARNING:** Only qualified and trained operators should install, adjust or use the assembly power tool for non-threaded mechanical fasteners.
- ⚠ WARNING:** Operator **MUST** read and understand all warnings and cautions.
- ⚠ WARNING:** It is required that eye protection, hearing protection and safety boots be worn at all times while handling this equipment.
- ⚠ WARNING:** The users or the user's employer should assess specific risks that could be present before each use based on their application.
 - *Be sure there is adequate clearance for tool and operator's hands before proceeding. Keep fingers clear of any moving parts. Keep fingers clear from fasteners and installed materials. Severe personal injury may result.*
 - *Verify the air lines and/or hydraulic hoses are not a trip hazard.*
 - *Ensure that there are no electrical cables, gas pipes, etc., which can cause a hazard if damaged by the tool.*
 - *Verify that hydraulic hose fittings and couplings, air and electrical connections are secure before each use.*
- ⚠ WARNING:** Do not carry from hoses or use as a hammer.
- ⚠ WARNING:** Do not use in explosive atmosphere.
- ⚠ WARNING:** Ensure air hose is securely connected to avoid possible hose whipping.
- ⚠ WARNING:** Always disconnect air supply, where applicable, when tool is not in use to prevent accidental start-up.
- ⚠ WARNING:** Do not operate when recommended pressures are exceeded as it could cause severe personal injury and or damage the equipment.
- ⚠ WARNING:** Use only Gage Bilt hydraulic hoses and couplings, or equivalent, rated for 10,000 psi. (689.48 bar) working pressure.
- ⚠ WARNING:** Proper PULL and RETURN pressures are important for proper function of installation tools. Severe personal injury or damage to equipment may occur without correct pressures. Pressure gage assy (942280) is available for checking these pressures. Set pressures per instructions furnished with applicable hydraulic installation tool instruction manual. See "setting pressures."
- ⚠ WARNING:** Hydraulic powerunits that deliver high pressure for both PULL & RETURN and are not equipped with relief valves are specifically not recommended, and may be dangerous.
- ⚠ WARNING:** Gage Bilt does not recommend making adjustments without using the pressure gage assy (942280).
- ⚠ CAUTION:** Do not use beyond the design intent.
- ⚠ CAUTION:** The pump is shipped without oil in the reservoir. Do not operate the pump without sufficient oil in the reservoir; instant damage to the pump will occur if ignored.
- ⚠ CAUTION:** Guard against exceeding above 60°C (140°F). Various commercial thermometers are available to monitor oil temperature in the reservoir. Continuous operation with reservoir oil temperatures in excess of 60°C (140°F) can cause permanent damage to the pump.
- ⚠ CAUTION:** Keep dirt and other foreign matter out of hydraulic systems of tools, hoses, couplers and powerunit. Do not let hose fittings and couplers contact a dirty floor or unclean working surface. Foreign matter in hydraulic oil may cause the tool and the powerunits valves to malfunction.

The tool is shipped with a red plastic plug in the air inlet connector. The connector has a 1/4-18 female pipe thread to accept user air hose fitting. To avoid poor performance and down time, keep foreign material from getting into the hydraulic system.

1. Clean area around plug (A-1122) before filling reservoir with hydraulic oil.
2. Remove plug (A-1122) .
3. Using a clean funnel fill reservoir with AW-32 or equivalent to 1/2 inch of the bottom of the reservoir cover.
4. Replace plug (A-1122).
5. Remove red plastic shipping plug from air inlet and screw in your disconnect fitting. Note: 1/4-18 n.p.t. thread required.
6. See lubrication. Lubricator is required for air supply.
7. Connect air supply.
8. Check tool manual for recommended hydraulic pressures. Set pressures accordingly using pressure setting gage assy (942280) (sold separately). See page 9,10 & 18 of this manual.
9. Connect hydraulic couplings from tool to pump. Note: Couplings must be clean and free of dirt.
10. Connect air actuator from tool to pump.
11. Cycle tool several times while examining tool and pump for any hydraulic leaks.
12. Select suitable nose assembly and attach to installation tool. Note: See tool manual for complete list of nose assemblies.

Operators should always compare the cubic inches of oil required by the tool against the cubic inches of oil available from the pump. Additional allowances should be made for the oil lost in hook up and bleeding of hoses and for long hoses. Each ten foot section of hose requires approximately 7.7 cubic inches of oil. This takes into account hose expansion due to pressurization.



LUBRICATION

Use a detergent SAE#10 automotive engine oil:

For proper operation and maximum service life, an automatic air line lubricator is installed in the air line just ahead of the air motor. The lubricator should be adjusted to feed one to three drops of oil for every minute, depending on usage, (Ref. one drop every 50-75 CFM of air going through the motor).

Lubrication is necessary for all internal moving parts and rust prevention. Excessive moisture in the airline can cause rust formation in motor and might also cause ice to form in the muffler due to expansion of air through motor. The moisture problem can be corrected by installing a moisture separator in the line and also by installing an aftercooler between the compressor and air receiver.

It is very **IMPORTANT** that the air motor not be allowed to “run free” at high speeds with no load and improper lubrication. Running under these conditions can cause excessive internal heat build up, loss of internal clearances and rapid motor damage.

CHECKING PULL PRESSURE

NOTE: The GB912 Powerunit should be checked, as required by the installation tool manual, at first time start-up, when troubleshooting and after overhauling directional valve or pump. For assisting in this procedure use Pressure Gage Assy (942280) (Sold separately). The Pressure Gage Assy (942280) is used to check the pressure settings for PULL and RETURN pressures. Personnel servicing the GB912 Powerunit should be given access to this gauge set-up. (See page 18 for pressure gage assy (942280).

The GB912 Powerunit is designed for high pressures for only a short period. Complete this check as quickly as possible.

1. Disconnect tool from GB912 power unit
2. Connect valve #1 of pressure gage to pull side of GB912 power unit
3. Open valve #1 (counter clockwise) and close valve #2 (clockwise)
4. Plug the air actuator from the installation tool into power unit.
5. Cycle tool to start the motor and directing hydraulic oil to pull side of power unit. And read gage pressure.

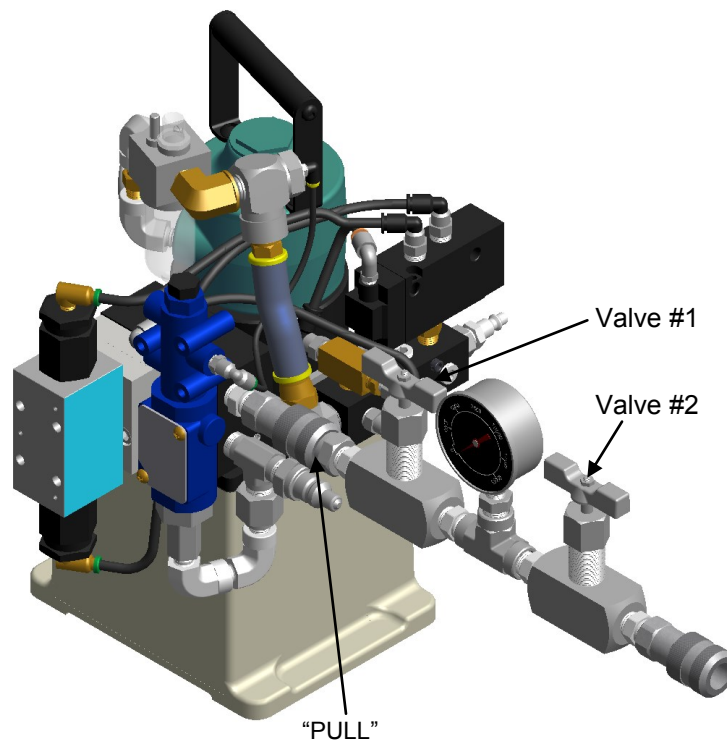
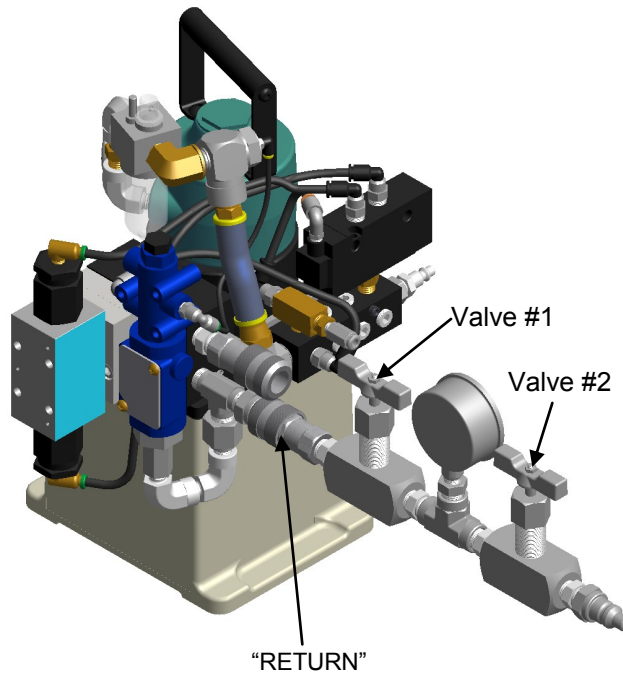

Image may not reflect actual tool.



CHECKING RETURN PRESSURE

1. Disconnect tool from GB912 power unit
2. Connect valve #2 of pressure gage to RETURN side of GB912 power unit
3. Open valve #2 (counter clockwise) and close valve #1 (clockwise)
4. Plug the air actuator from the installation tool into power unit.
5. Cycle tool to start the motor, releasing air actuator will direct hydraulic oil to return side of power unit, read gage pressure at highest point.



SETTING OR ADJUSTING OUTPUT PRESSURES

PULL Pressure Procedure:

1. Turn adjusting screw in, to increase PULL pressure.
2. Turn adjusting screw out, to decrease PULL pressure.

Adjusting Screw

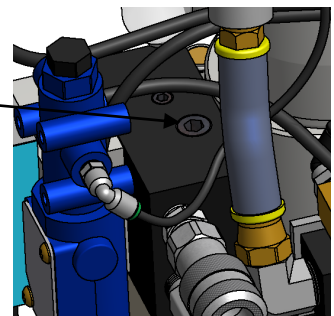

RETURN Pressure Procedure:

1. Loosen 2 screws on name plate on top of return pressure switch (A-1078).
2. Swivel name plate to the side.
3. Use 2 pin punch's to loosen lock washer.
4. Tighten or loosen adjusting nut against spring to increase or decrease return pressure. Tightening or compressing spring will increase return pressure. Once pressure is set tighten lock nut against adjusting nut.
Note: A minimum RETURN pressure of 2,400 psi. (165.5 bar) is required in order for pump to shut off.

A-1078 Return pressure switch

Name plate

Name plate Screws

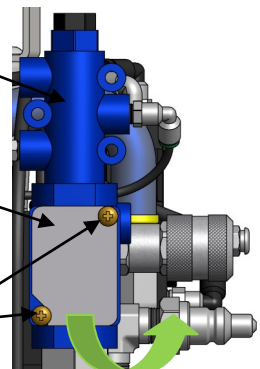

Images may not reflect actual tool.



FILLING THE RESERVOIR

1. Clean the area around plug (A-1122) to remove all dust and grit. Any dirt or dust in the oil can damage the pump.
2. Remove the plug (A-1122) and fill with fire resistant hydraulic oil AW-32 or equivalent to within 1/2" (12.70mm) from top plate of reservoir. Replace plug (a-1122).
3. Connect the PULL pressure hose to the output marked PULL. Connect the RETURN to the output marked RETURN.
4. Operate unit at 90-100 psi (6.2-6.9 bar) air pressure with a minimum hose ID of 1/2".
5. Cycle the pump (with tool attached) several times. Re-check the oil level in the pump reservoir with the tool in the relaxed (return) position.
6. Check for leaks.
7. Always keep filler hole closed with the filler plug to prevent airborne dust from entering the reservoir.
8. The GB912 powerunit and installation tool are ready for attaching the applicable nose assembly.

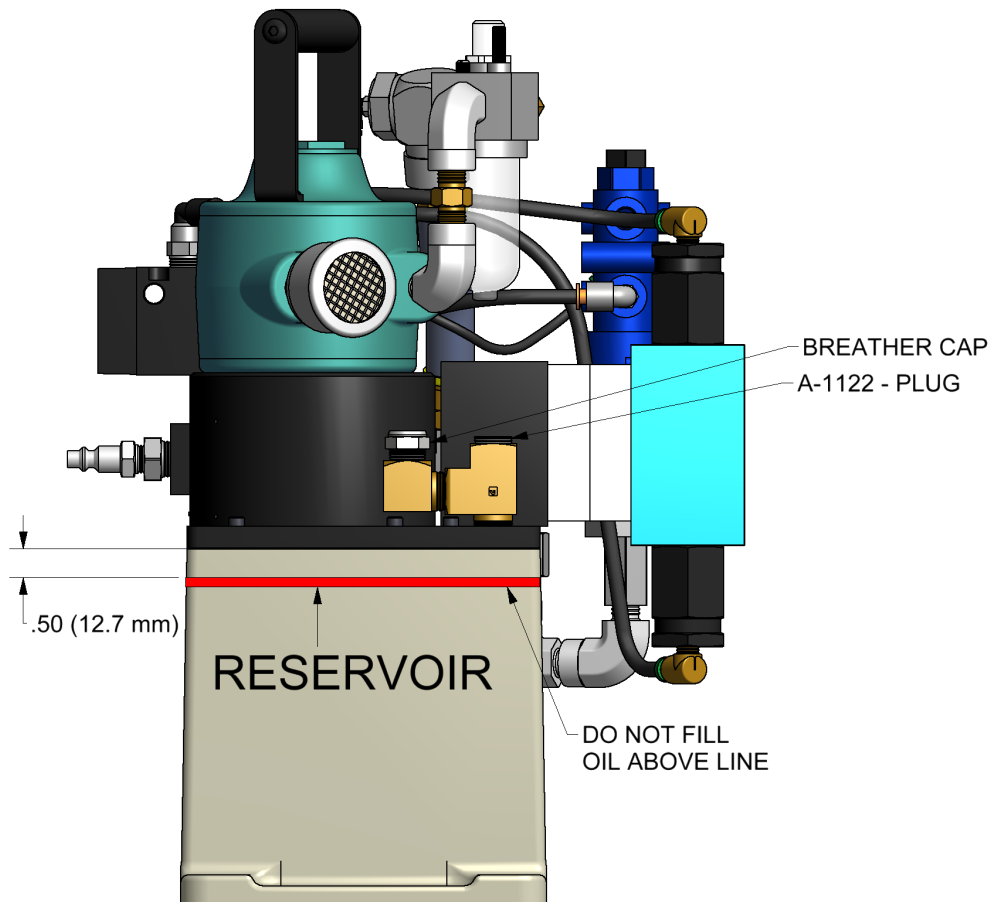

RESERVOIR TEMPERATURE CONTROL CAUTION

Guard against exceeding above 60°C (140°F). Various commercial thermometers are available to monitor oil temperature in the reservoir. Continuous operation with reservoir oil temperatures in excess of 60°C (140°F) can cause permanent damage to the pump.

- a. At oil temperatures above 60°C (140°F) HA-57 oil tends to thin and lose its ability to provide an adequate oil film in the ball bearings and between various precision sliding surfaces in the pump mechanism. Furthermore, the oil additives tend to break down at continuous operations above 60°C (140°F) reducing effectiveness of sealing materials.
- b. Should over heating occur: Consider replacing the 1/2 gallon reservoir with a two gallon reservoir which has a higher heat dissipating capacity. In general, a two gallon reservoir will take twice as long to reach 60°C (140°F) as a 1/2 gallon reservoir.



- ⚠ WARNING:** Only qualified and trained operators should install, adjust or use the assembly power tool for non-threaded mechanical fasteners.
- ⚠ WARNING:** Operator **MUST** read and understand all warnings and cautions.
- ⚠ WARNING:** It is required that eye protection, hearing protection and safety boots be worn at all times while handling this equipment.
- ⚠ WARNING:** The users or the user's employer should assess specific risks that could be present before each use based on their application.
 - *Be sure there is adequate clearance for tool and operator's hands before proceeding. Keep fingers clear of any moving parts. Keep fingers clear from fasteners and installed materials. Severe personal injury may result.*
 - *Verify the air lines and/or hydraulic hoses are not a trip hazard.*
 - *Ensure that there are no electrical cables, gas pipes, etc., which can cause a hazard if damaged by the tool.*
 - *Verify that hydraulic hose fittings and couplings, air and electrical connections are secure before each use.*
- ⚠ WARNING:** Do not carry from hoses or use as a hammer.
- ⚠ WARNING:** Do not use in explosive atmosphere.
- ⚠ WARNING:** Ensure air hose is securely connected to avoid possible hose whipping.
- ⚠ WARNING:** Always disconnect air supply, where applicable, when tool is not in use to prevent accidental start-up.
- ⚠ WARNING:** Do not operate when recommended pressures are exceeded as it could cause severe personal injury and or damage the equipment.
- ⚠ WARNING:** Use only Gage Bilt hydraulic hoses and couplings, or equivalent, rated for 10,000 psi. (689.48 bar) working pressure.
- ⚠ WARNING:** Proper PULL and RETURN pressures are important for proper function of installation tools. Severe personal injury or damage to equipment may occur without correct pressures. Pressure gage assy (942280) is available for checking these pressures. Set pressures per instructions furnished with applicable hydraulic installation tool instruction manual. See "setting pressures."
- ⚠ WARNING:** Hydraulic powerunits that deliver high pressure for both PULL & RETURN and are not equipped with relief valves are specifically not recommended, and may be dangerous.
- ⚠ WARNING:** Gage Bilt does not recommend making adjustments without using the pressure gage assy (942280).
- ⚠ CAUTION:** Do not use beyond the design intent.
- ⚠ CAUTION:** The pump is shipped without oil in the reservoir. Do not operate the pump without sufficient oil in the reservoir; instant damage to the pump will occur if ignored.
- ⚠ CAUTION:** Keep dirt and other foreign matter out of hydraulic systems of tools, hoses, couplers and powerunit. Do not let hose fittings and couplers contact a dirty floor or unclean working surface. Foreign matter in hydraulic oil may cause the tool and the powerunits valves to malfunction.

Lockbolts

#1. Insert fastener through the work piece.



#2. Slide collar over fastener.



#3. Insert fastener into nose assembly.



#4. Press actuator to start cycle.

#5. Release actuator as soon as fastener breaks.

#6. Repeat steps 1-5.

Images may not reflect actual tool or fastener.

Blind Fasteners

1. Insert fastener.



2. Insert fastener into nose assembly.

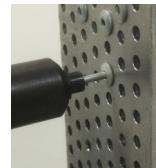

3. Press actuator to start cycle.

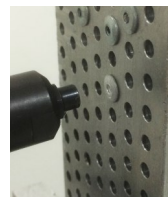

4. Release actuator as soon as fastener breaks.

5. Repeat steps 1-4.

DAILY MAINTENANCE



- ⚠ WARNING:** Pump must be maintained in a safe working condition at all times and examined on a daily basis for damage or wear. Any repair should be done by qualified personnel trained on Gage Bilt procedures.
- ⚠ WARNING:** Excessive contact with hydraulic oil and lubricants should be avoided.
- ⚠ WARNING:** Maintenance personnel **MUST** read and understand all warnings and cautions.
- ⚠ WARNING:** Disconnect pump from its power source before performing maintenance, cleaning or when replacing worn or damaged components. Severe personal injury may occur if power source is not disconnected.
- ⚠ WARNING:** Read SDS documents for all applicable materials.

Note:

- Dispose of hydraulic oil in accordance with manufacture safety datasheet.
- All tool materials are recyclable except rubber o'rings, seals and wipers.

The performance of any tool depends upon good maintenance practices. Following these minimal requirements daily will extend the life of your pump.

- *Inspect lubricator for proper operation. (See page 8).
- *Ensure air supply is clean, dry and set at 90-100 p.s.i. (6.2-6.9 bar). Use filter-regulator if required.
- * Inspect hoses and couplings for wear, damage and leaks. (Replace/Repair if necessary).
- * Verify that hydraulic hose fittings and couplings, air and electrical connections are secure. Tighten, Replace or Repair if necessary
- * Cycle the tool several times to assure there are no leaks during use.
- * Keep hydraulic system and exterior surface free of dirt.
- * Proper care by operators is necessary in maintaining full productivity and reducing downtime.
- * Any unusual differences noted, would suggest this course of action before further operation: Drain and discard used oil. Refill with new oil.
- * Check oil level in reservoir.
- * Check oil level in lubricator.

WEEKLY MAINTENANCE

Keep the hydraulic system full. Change oil every 100 hours. The following conditions would warrant more frequent changes:

- a) Very dusty environment and dust enters reservoir.
 - b) Hourly operations near 60°C (140°F) - evidence of oxidation and formation of gum, sludge and/or varnish.
 - c) Exposure to frequent extreme temperature changes and high humidity resulting in excessive condensation in the reservoir while in storage.
- * Clean filter screen in the bottom of the reservoir every 50 hours of operation or as required. Note: Replace damaged filter screen.
- * The large filler hole provides easy access for examining the quality of the oil. A quick and easy field check of the oil would consist of a comparison against new unused oil as follows:
- a) Visual Inspection: Presence of contaminants liquid or solid. Color, new oil versus used oil.
 - b) Odor Inspection: New oil versus used oil.
 - c) Touch Inspection: New oil versus used oil, rub between fingers checking for grittiness, etc.

SEE TROUBLESHOOTING AND OVERHAUL FOR FURTHER GUIDANCE.



Providing all maintenance conditions have been met, follow this systematic approach to diagnosis.

1. Tool will not reciprocate when motor is running.
 - a) Improperly coupled hoses.
 - b) Bind in tool or nose assembly.
 - c) Pump to motor coupling damaged.
 - d) Hydraulic oil level is low or viscosity not proper.
 - e) Unloading valve in tool improperly installed or missing.
2. Fastener pintail fails to break off.
 - a) PULL pressure set too low.
 - b) Defective hose couplers.
 - c) Defective tool or nose assembly.
 - d) Overheated hydraulic oil.
 - e) Hydraulic oil level low or viscosity not proper.
 - f) Defective pump.
3. Tool will not return or push nose assembly off swaged fastener when switch is released.
 - a) RETURN pressure set too low.
4. When the installation cycle is complete, motor fails to shut off.
 - a) RETURN pressure switch set too high or too low.
 - b) Overheated hydraulic oil.
 - c) Hydraulic oil level low or viscosity not proper.
 - d) Defective RETURN pressure switch.
5. Pump making noise throughout operating cycle.
 - a) Pump is cavitating, the oil viscosity is too heavy or the oil level may be too low.
 - b) Filter is clogged or dirty.
6. Tool operates slow throughout entire cycle.
 - a) Pump is cavitating, the oil viscosity is too heavy or the oil level may be too low.
 - b) Filter is clogged or dirty.
 - c) Defective pump.

OVERHAUL



- ⚠ WARNING:** Only qualified and trained personnel should perform overhaul.
- ⚠ WARNING:** Personnel must read and understand all warnings and cautions.
- ⚠ WARNING:** Pump must be maintained in a safe working condition at all times and examined on a daily basis for damage or wear. Any repair should be done by qualified personnel trained on Gage Bilt procedures.
- ⚠ WARNING:** Disconnect pump from its power source before performing overhaul. Severe personal injury may occur if power source is not disconnected.
- ⚠ WARNING:** Excessive contact with hydraulic oil and lubricants should be avoided (See SDS documents for all applicable materials).
- ⚠ WARNING:** When operating, repairing or overhauling pump, wear approved eye protection.

Note:

- Dispose of hydraulic oil in accordance with manufacture safety datasheet.
- All tool materials are recyclable except rubber o'rings, seals and wipers.

*Contact Gage Bilt for a complete and thorough overhaul of your GB912 powerunit.

PUMP DISPOSAL

1. When pump life is met, drain hydraulic oil from tool and dispose of the hydraulic oil in accordance with SDS datasheet.
2. Disassemble pump and remove all rubber o'rings, seals, wipers and hydraulic hoses. All tool materials are recyclable except rubber o'rings, seals, wipers and hydraulic hoses. Dispose of rubber materials in accordance with all environmental regulations applicable in your area.

PARTS LIST

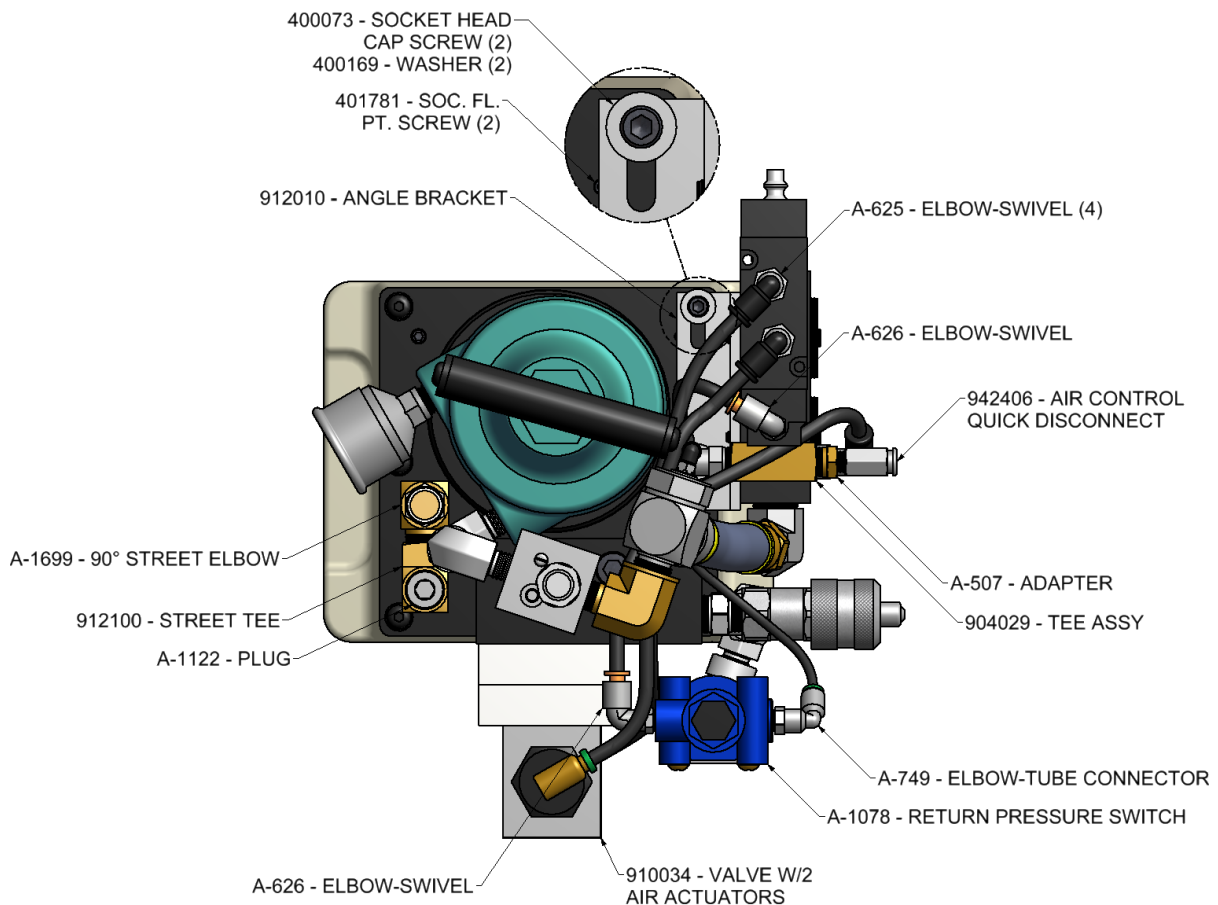

PARTS LIST

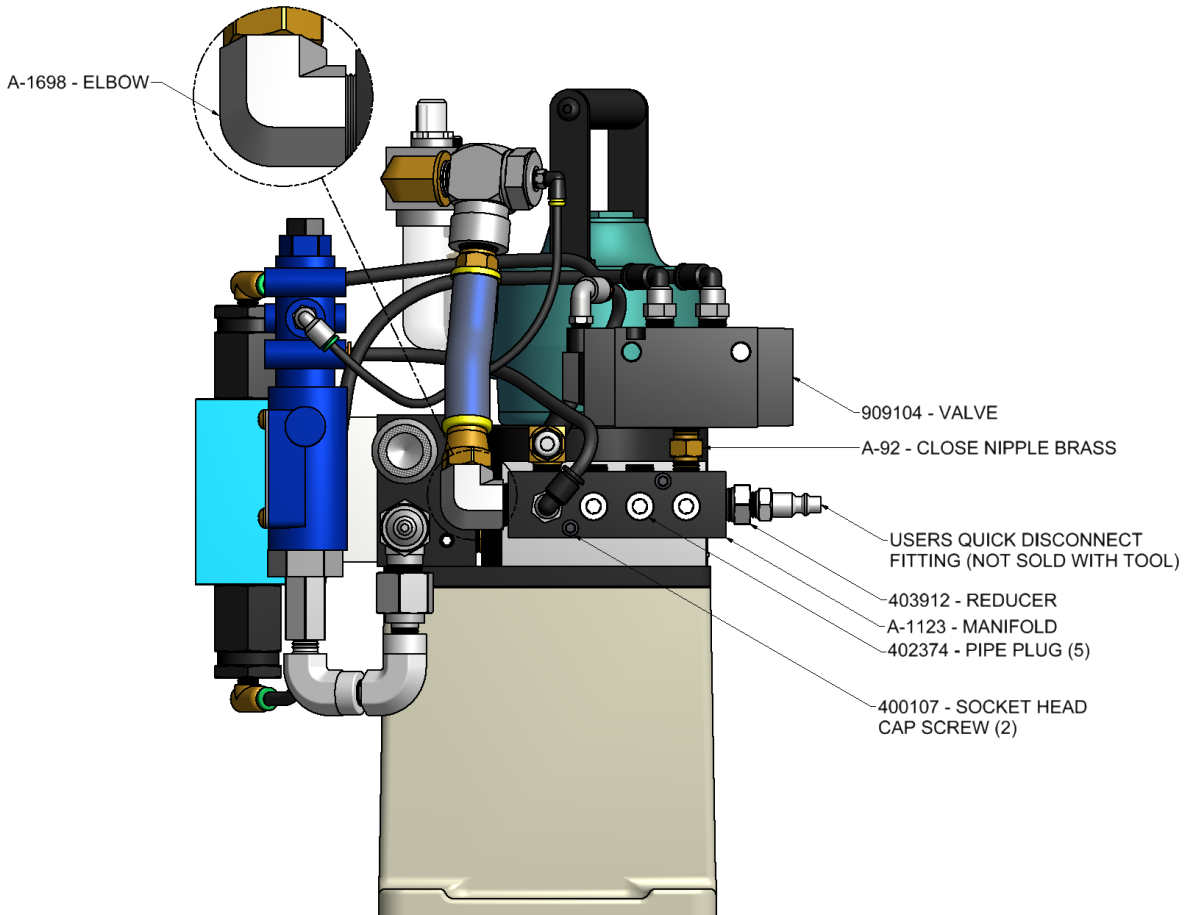
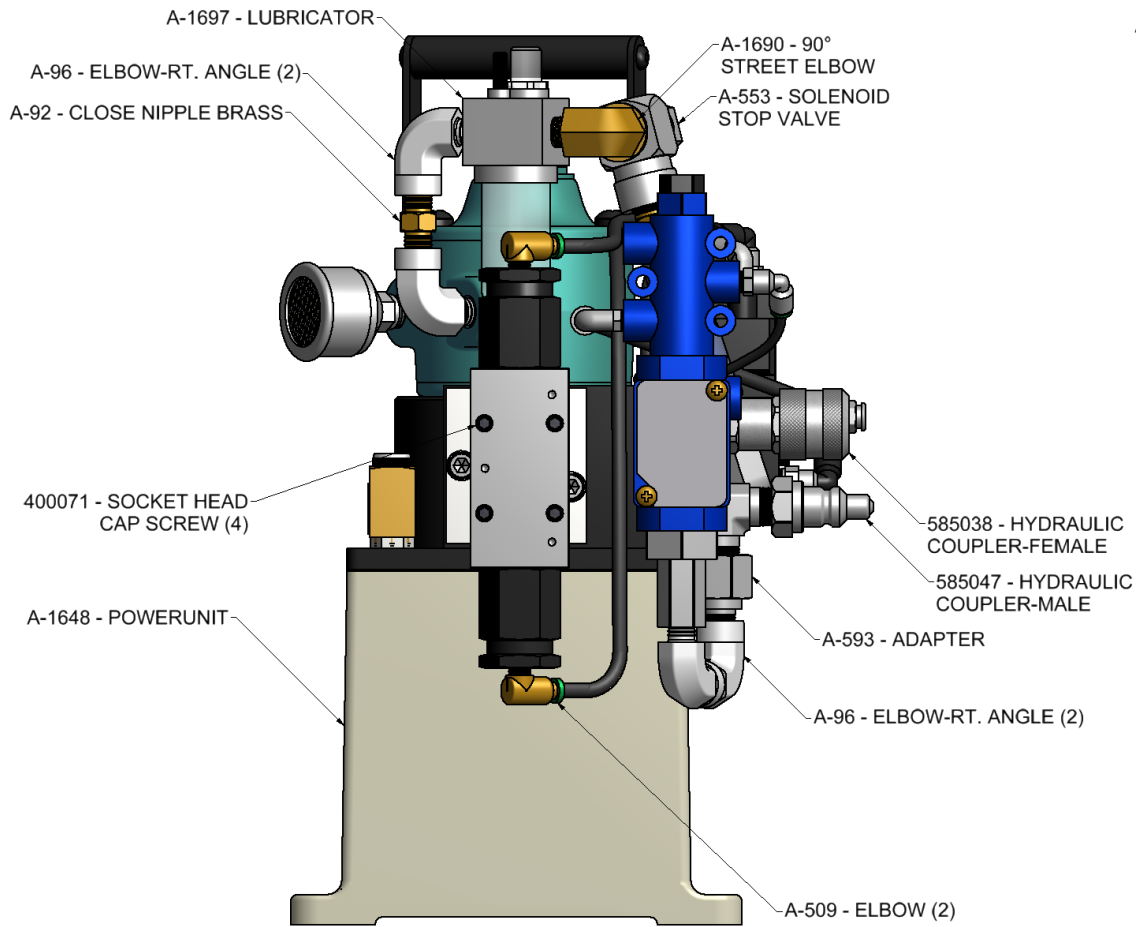

PARTS LIST

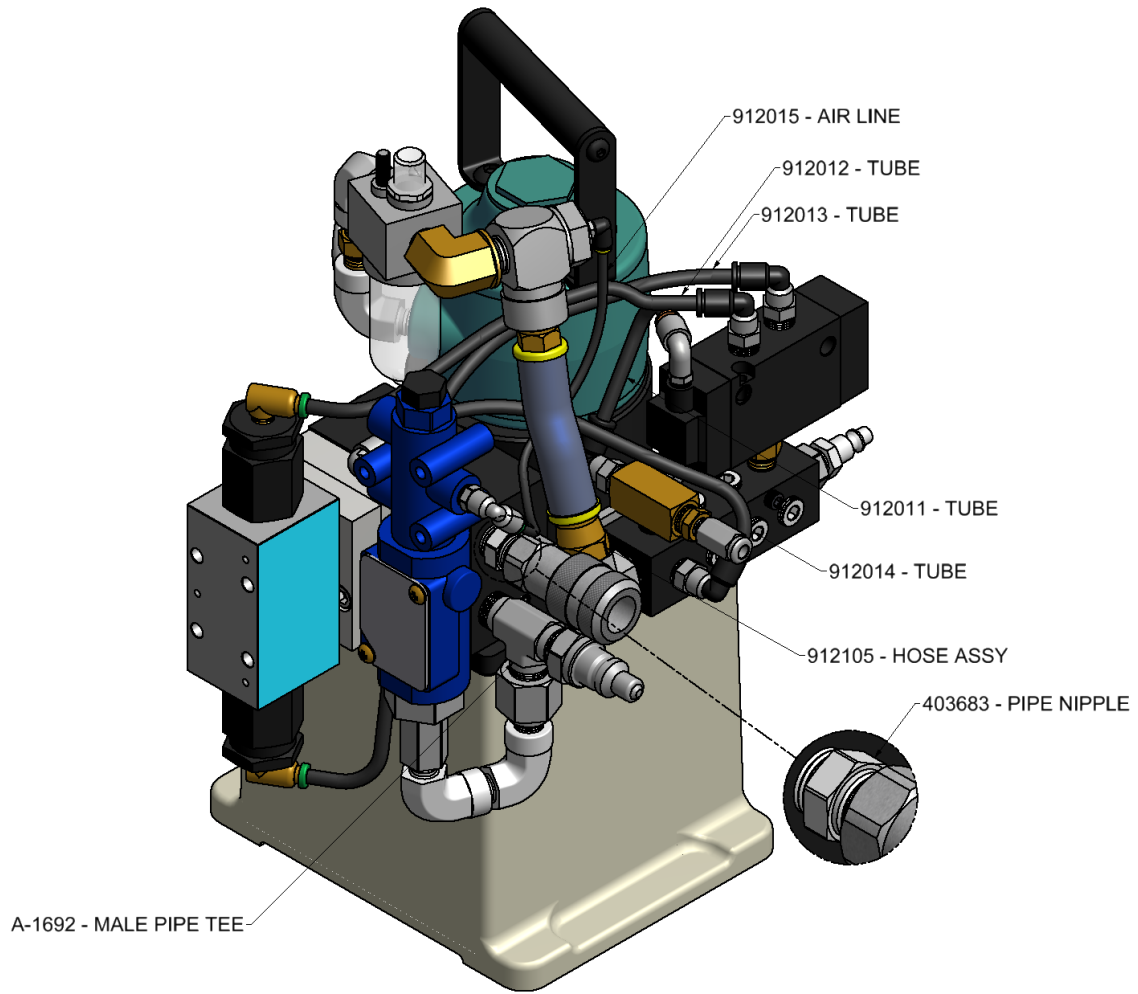

ACCESSORIES

(Sold Separately)



PARTS LIST- GAGE SET-UP

Part Number	Qty.	Description
407299	1	Gage - 10,000 psi
403912	1	Reducer
*585047	1	Hydraulic Coupler-male
403683	4	Pipe Nipple
403368	2	Shut-off Valve
403911	1	Tee
*585038	1	Hydraulic Coupler-female

* 585038 & 585047 are available in sets as Hydraulic Coupling Assy (585037)

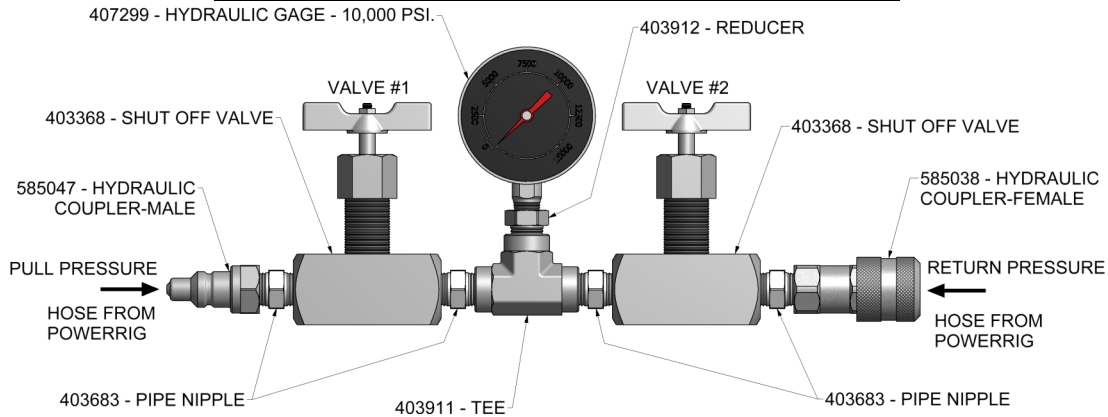

PRESSURE SETTING GAGE ASSY (942280)
(Sold Separately)

GB910 POWERUNIT



The GB910 Hydraulic Powerunit is a portable power source designed to operate a wide range of hydraulic installation tools. The unit is air powered, air actuated and delivers up to 10,000 psi working pressure.

The GB910 Hydraulic Powerunit is available separately or in kits including hydraulic quick-disconnect couplers, air connectors, air lines and hydraulic hoses in various lengths.

- GB910-12: GB910 and pt# 910701(12 ft.) Hose Kit-Air
- GB910-26: GB910 and pt# 910705 (26 ft.) Hose Kit-Air
- GB910-38: GB910 and pt# 910709 (38 ft.) Hose Kit-Air
- GB910-52: GB910 and pt# 910714 (52 ft.) Hose Kit-Air,

GB940 POWERUNIT



The GB940 Hydraulic Powerunit is a light-weight, portable power source designed to operate on a wide range of hydraulic installation tools. The unit is electrically powered and delivers up to 10,000 psi working pressure with simple adjustable hydraulic outputs.

The GB940 Hydraulic Powerunit is available separately or in kits including hydraulic quick-disconnect couplers, electrical connectors and hose cord kits in various lengths.

- GB940-12: GB940 and pt# 940701 (12 ft.) Hose Kit
- GB940-26: GB940 and pt# 940705 (26 ft.) Hose Kit
- GB940-38: GB940 and pt# 940709 (38 ft.) Hose Kit
- GB940-52: GB940 and pt# 940714 (52 ft.) Hose Kit



Alternative Styles

Compatible with Gage Bilt and Huck® Air/hydraulic installation tools

GB808
POWERUNIT
(Sold Separately)

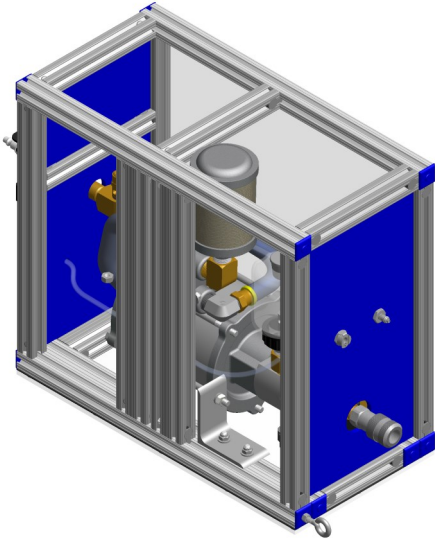

GB808V
POWERUNIT WITH VACUUM
(Sold Separately)

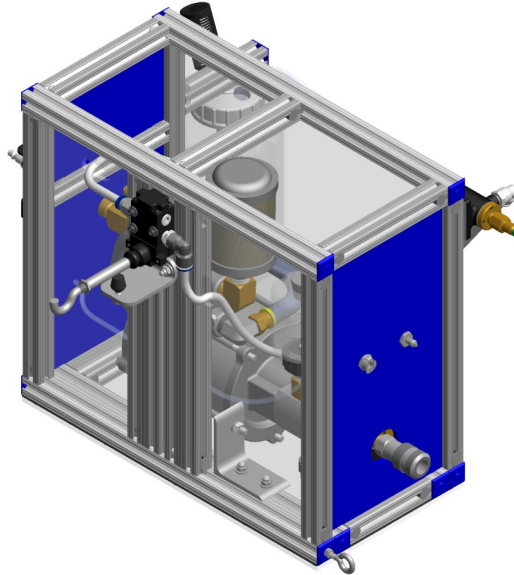

GB808HVB
HANGING POWERUNIT WITH VACUUM
(Sold Separately)

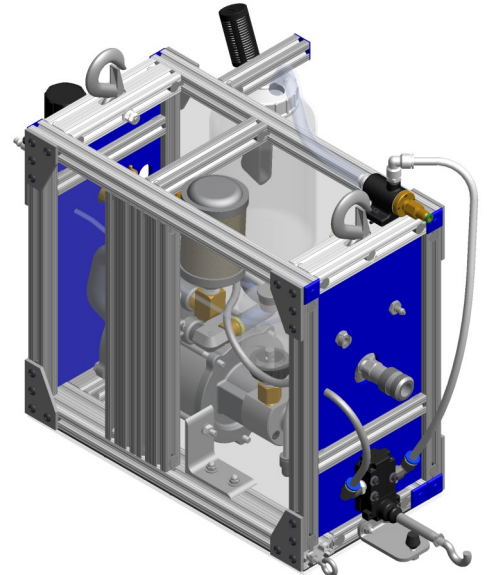

*GB808 WHEELS OPTIONAL

Hose Kits available to 26 ft (7.92 m)
Pressure 4,000 lbs. (177.93kN) @ 90 PSI (6.2 bar)
Fast Acting Cylinder
Requires 1/2" (12.7 mm) Air Hose
POWER: 80-100 PSI compressed air (5.2-6.9 bar)
GB808 Dimensions & weight shown below.
For all other models dimensions & weights contact Gage Bilt.
WEIGHT: 40 lbs (18.1)
HEIGHT: 16.5" (419.1 mm)
WIDTH: 9.0" (228.6 mm)

Images may not reflect actual tool

GB940 GB940-220* HYDRAULIC POWERUNIT

MASTER DISTRIBUTOR



advancecomponents.com 972.446.5500



*Wheeled Cart #A-1696 available for GB940/GB940-220
Not shown
Sold separately*

The GB940 (115 volt single phase, alternating current) Hydraulic Powerunit is a light-weight, portable power source designed to operate on a wide range of hydraulic installation tools. The unit is electrically powered and delivers up to 10,000 psi (689.5 bar) working pressure with simple adjustable hydraulic outputs. The 24 volt remote control circuit, in the installation equipment, controls the pump output directional valve. Output pressures as shipped are: PULL 5,400-5,700 psi, (372.3 - 393.0 bar) RETURN 2,200-2,400 psi (151.7 - 165.5 bar).

The GB940-220 (230* volt, single phase, alternating current) Hydraulic Powerunit is a light-weight, portable power source designed to operate on a wide range of hydraulic installation tools. The unit is electrically powered and delivers up to 10,000 psi (689.5 bar) working pressure with simple adjustable hydraulic outputs. The 24 volt remote control circuit, in the installation equipment, controls the pump output directional valve. Output pressures as shipped are: PULL 5,400-5,700 psi, (372.3 - 393.0 bar) RETURN 2,200-2,400 psi (151.7 - 165.5 bar).

The GB940 & GB940-220 Hydraulic Powerunits are available separately or in kits including hydraulic quick-disconnect couplers, electrical connectors and hose cord kits in various lengths.

GB940-12 includes the GB940 Powerunit and 12 ft. Hose Kit, part #940701.

GB940-26 includes the GB940 Powerunit and 26 ft. Hose Kit, part #940705.

GB940-38 includes the GB940 Powerunit and 38 ft. Hose Kit, part #940709.

GB940-52 includes the GB940 Powerunit and 52 ft. Hose Kit, part #940714.

GB940-220-12 includes the GB940-220 Powerunit and 12 ft. Hose Kit, part #940701.

GB940-220-26 includes the GB940-220 Powerunit and 26 ft. Hose Kit, part #940705.

GB940-220-38 includes the GB940-220 Powerunit and 38 ft. Hose Kit, part #940709.

GB940-220-52 includes the GB940-220 Powerunit and 52 ft. Hose Kit, part #940714.

GAGE BILT
 **MADE in USA**

 advancecomponents.com 972-446-5500

Width.....10.5 inches.....267mm
Length.....12.5 inches.....318mm
Height.....18.1 inches.....460mm
Weight (without hyd. fluid).....66 pounds.....30kg
Electrical System.....115 volts, 50/60 hertz, single phase, AC
230 volts, 50/60 hertz, single phase, AC
Remote Control.....Solenoid operated Directional Valve, 24 volts
Motor.....12,000 RPM, 1-1/8 HP, 20 amps nom.
PUMP.....2 - stage, Gear-Piston Type, 70 cu.in./min. @ 5000 psi
Output Pressure.....Adjustable to 10,000 psi.

(Shipped with PULL pressure at 5400-5700 psi (37350-39300 kPa)
and the RETURN pressure at 2200-2400 psi (15200-16500 kPa).

Reservoir Capacity.....1-1/2 gal.....006m
Operating Temperature (Ambient-min.) 0 F.....-18 C
(Hydraulic Fluid-max.)..... 250 F.....65 C

Installation tools powered by the GB940 Powerunit are:

GB204	GB7624	2600	7042
GB205	209	4802	7142
GB206-500	506	4803	7304
GB208-625	507	5304	8042
GB585	586	5901	8304
GB500 SERIES	GB2480	6042	9304
GB2628	GB2581	6304	12142
GB7720	GB2630	GB2620	GB2620PT

Collar Cutters powered by the GB940/GB940-200 Powerunit are:

516 520 524 532 536

WARRANTY

Seller warrants that all goods covered by this catalog will conform to applicable specifications and will replace or repair, EXW. our plant, any goods providing defective from faulty workmanship, or material, for 1 year from date of shipment.

Said warranty to remain in effect if, and only if, such goods are used in accordance with all instructions as to maintenance, operation and use, set forth in manuals and instruction sheets furnished by seller.

Sellers obligation under this warranty shall be limited to the repair or rework of the goods supplied or replacement thereof, at Seller's option, and in no case is to exceed the invoice value of said goods. Under no circumstances will the seller be liable for incidental or consequential damages or for damages incurred by the buyer or subsequent user in repairing or replacing defective goods or if the goods covered by this warranty are reworked or subjected to any type of additional processing.

This warranty is void if Seller is not notified in writing of any rejections or defects within 1 year after the receipt of the material by the customer.

THIS WARRANTY IS MADE IN LIEU OF ALL OTHER WARRANTIES EXPRESSED OR IMPLIED, INCLUDING MERCHANTABILITY.