

ORIGINAL INSTRUCTIONS

GB947/GB947-220

HYDRAULIC POWERUNIT



GAGE BILT TOOLS ARE AVAILABLE WORLDWIDE
E-MAIL US FOR A DISTRIBUTOR NEAR YOU.

Registered to
ISO 9001:2015

GAGE BILT
 **MADE in USA**

44766 Centre Court Clinton Twp. MI 48038 USA
Ph: +1 (586) 226-1500 Fax: +1 (586) 226-1505
solutions1@gagebilt.com / www.gagebilt.com



	<u>Page</u>
Warranty.	3
Description and Technical Specifications	4
Description of Functions	5
Warnings.....	6
Principle of Operation	7
How to set-up the GB947.....	8
How to set-up the GB947 (Pressure Setting & Pressure Setting Gage).....	9
How to set-up the GB947 (Adjusting & Setting Output Pressure & Checking PULL & RETURN Pressure).....	10
How to set-up the GB947 (Filling and Draining the Reservoir / Reservoir Temperature Control Caution)	11
Maintenance	12
Maintenance Cont. (Inspecting & Replacing Motor Carbon Brushes).....	13
Troubleshooting	14-15
Parts lists.....	16-22
Solenoid Valve Assembly Bolt Pattern / Parts List.....	23
DEXRON® III Oil Safety Data (SDS)	24
Accessories / Alternative Power Units.....	25-28



WARRANTY

Seller warrants that all goods covered by this catalog will conform to applicable specifications and will replace or repair, EXW our plant, any goods providing defective from faulty workmanship, or material, for 1 year from date of shipment.

Said warranty to remain in effect if, and only if, such goods are used in accordance with all instructions as to maintenance, operation and use, set forth in manuals and instruction sheets furnished by seller.

Sellers obligation under this warranty shall be limited to the repair or rework of the goods supplied or replacement thereof, at Seller's option, and in no case is to exceed the invoice value of said goods. Under no circumstances will the seller be liable for incidental or consequential damages or for damages incurred by the buyer or subsequent user in repairing or replacing defective goods or if the goods covered by this warranty are reworked or subjected to any type of additional processing.

This warranty is void if Seller is not notified in writing of any rejections or defects within 1 year after the receipt of the material by the customer.

THIS WARRANTY IS MADE IN LIEU OF ALL OTHER WARRANTIES EXPRESSED OR IMPLIED, INCLUDING MERCHANTABILITY.

DESCRIPTION



⚠ WARNING: Any other use is forbidden.

The GB947 Powerunit is a portable, electronically operated hydraulic power source designed to operate Gage Bilt hydraulic installation equipment. It is also compatible with HUCK® hydraulic installation equipment.

The GB947 Powerunit operates in 115 volt, 50/60 hertz, single phase, alternating current. The GB947-220 Powerunit operates in 230 volt, 50/60 hertz, single phase, alternating current.

Hydraulic pressure is developed by a two-stage, gear piston hydraulic pump driven by a 1-1/2 hp electric motor. Pump output is directed to either the PULL or RETURN pressure ports of the installation equipment by a four-way directional valve. The directional valve is controlled from the installation equipment by a 24-volt control system.

For the protection of the equipment and operator, an internal relief valve is pre-set at the factory. An external relief valve controls the PULL pressure. A pressure switch controls the RETURN pressure and automatically turns off the GB947 Powerunit. When the actuator is released, the installation cycle is finished.

As shipped by factory, the external relief valve is set at 5,400 - 5,700 psi (37,250 - 16,500 kPa) and the pressure switch is set at 2,200 - 2,400 psi (15,200 - 16,500 kPa).

ENVIRONMENTAL USE

⚠ WARNING: Do not operate in an explosive atmosphere.

The GB947 can be operated between -20°F - 122°F (-29°C / 50°C).

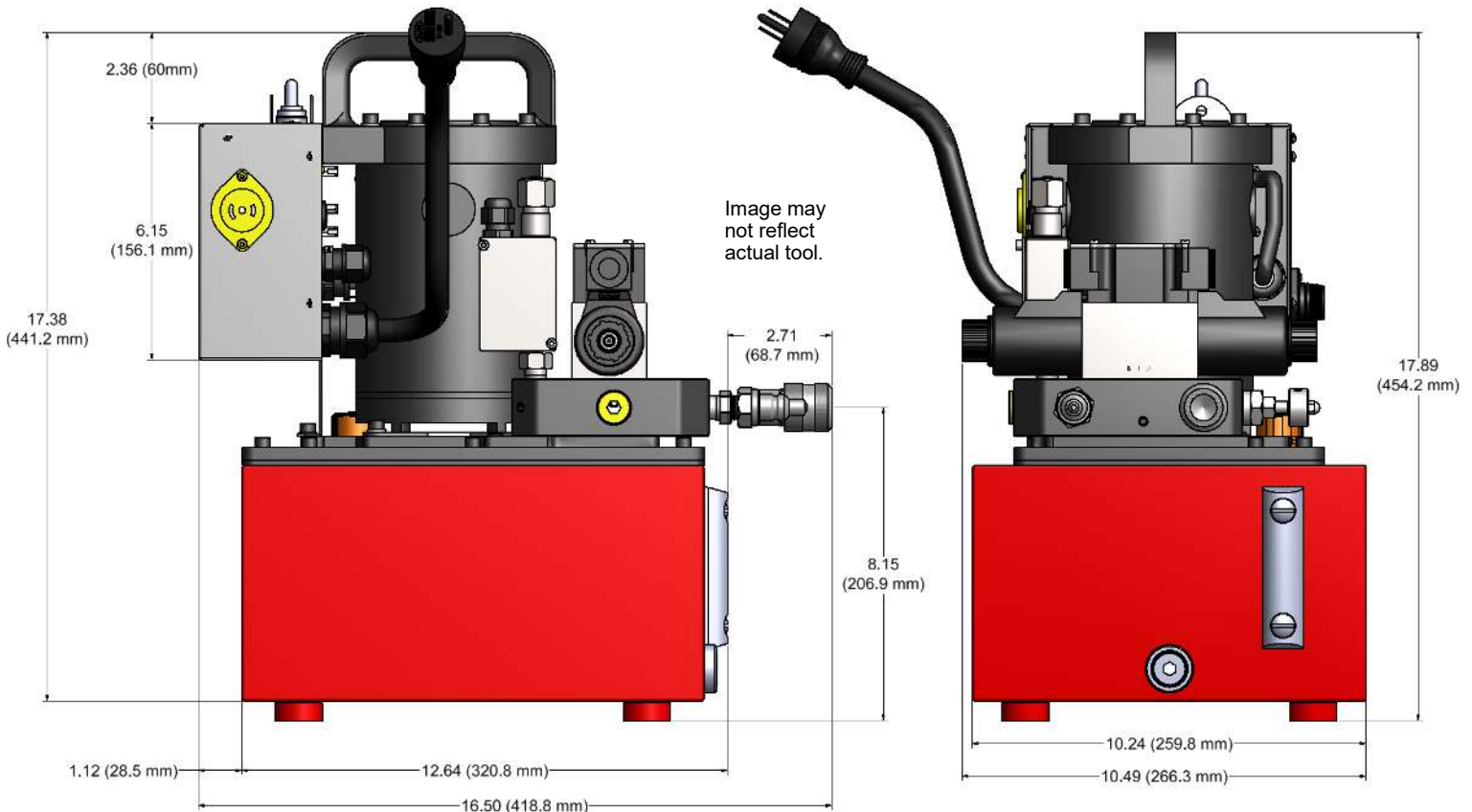

SPECIFICATIONS

Weight without oil	- 52 lbs. (23.6 kg)
Weight with oil	- 62 lbs. (28.1 kg)
Hydraulic oil	- DEXRON III, or equivalent.
Motor Voltage	- 120VAC, 50/60HZ, 20 AMP Circuit - 230VAC, 50/60HZ, 20 AMP Circuit
Output Pressure	- Adjustable to 10,000 psi. (68,947.6 kPa) (shipped with PULL pressure 5,700 (39,300 kPa) (shipped with RETURN pressure 2,400 (16,500 kPa)
Noise level	- 90 dB(A)
Vibration	- Tested – No hazards found

DESCRIPTION OF FUNCTIONS

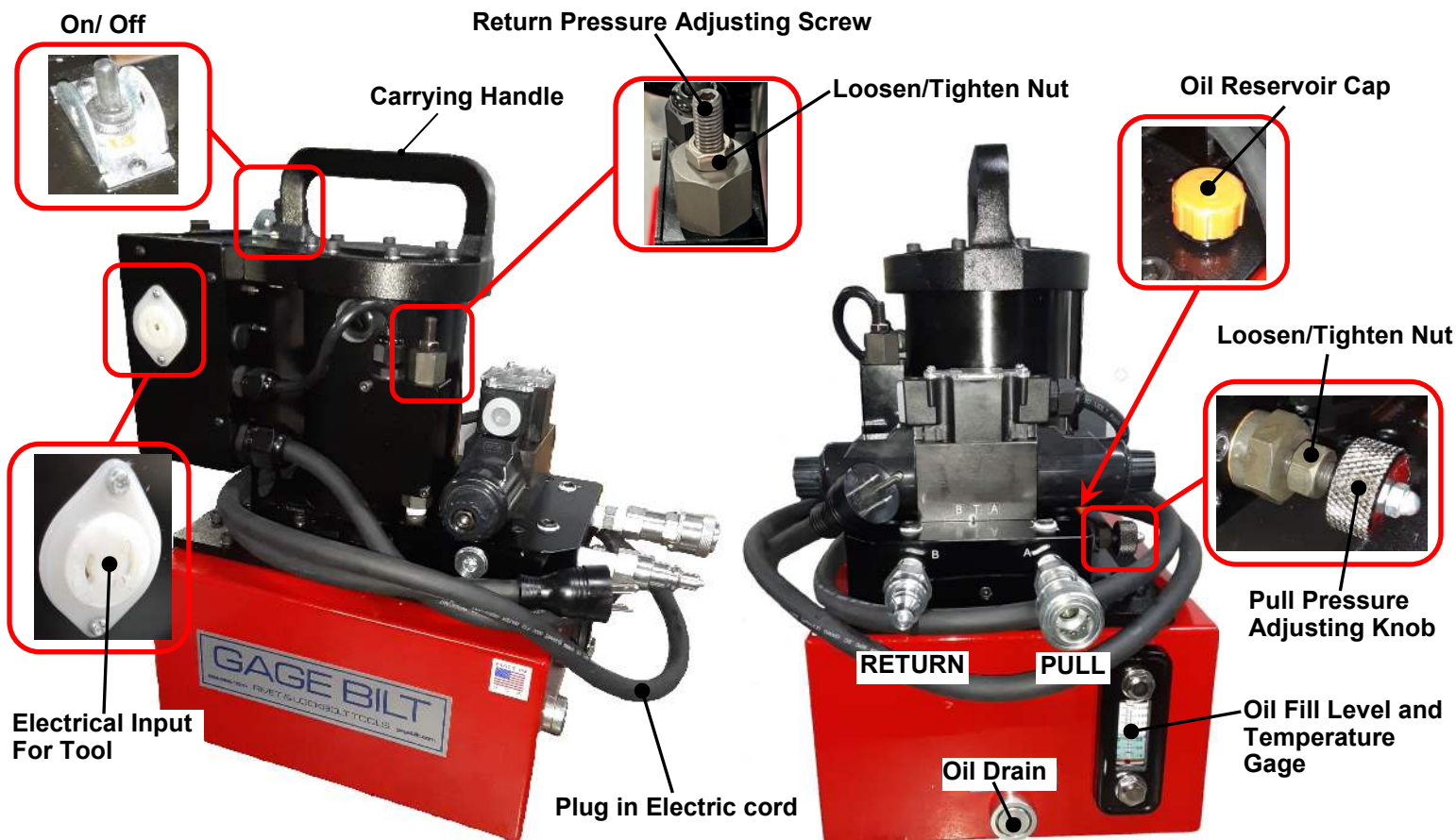

Width.....	10.5 inches.....	267 mm
Length.....	13.9 inches.....	352 mm
Height.....	17.9 inches.....	454 mm
Weight (without hyd. oil).....	52.0 pounds.....	23.6 kg
Weight (with hyd. oil).....	62.0 pounds.....	28.1 kg
Reservoir Capacity.....	2.5 gallons.....	9.5 Liter
Electrical system.....	120 volts, 50/60 hertz, single phase, AC	
	230 volts, 50/60 hertz, single phase, AC	
Remote control.....	solenoid operated Directional Valve 115 volts or 230 volts	
Motor.....	12,000 RPM, 1-1/2 HP, 25 amps. nom.	
Pump.....	2-STAGE, Gear-Piston Type, 75 cu. in./min. @ 5000 psi.	
Output Pressure.....	Adjustable to 10,000 psi. (689.5 bar).	

(Shipped with PULL pressure at 5,400 - 5,700 psi. (37,350 - 39,300 kPa)
and the RETURN pressure at 2,200 - 2,400 psi. (15,200 - 16,500 kPa).

Hydraulic Oil: Standard hydraulic oil with a viscosity rating of 300 SUS @ 100 deg. F. and 50 SUS @ 210 deg. F.

Hydraulic Oil is not supplied by Gage Bilt. Use automatic transmissions oil, DEXRON III®, or equivalent. Fire resistant hydraulic oil must be used to comply with OSHA regulation 1926.302 paragraph (d): "the fluid used in hydraulic power tools shall be fire resistant fluid approved under Schedule 30 of the US Bureau of Mines, Department of Interior, and shall retain its operating characteristics at the most extreme temperatures to which it will be exposed." Fluid viscosity 300 SUS @ 100°F and 50 SUS @ 210° F is recommended for ambient temperatures 0 to 130° F.



TERMS AND SYMBOLS



- Product complies with requirements



- Product complies with requirements



- Hearing protection and eye protection



- Read manual prior to using equipment



- Wear safety boots



WARNINGS - Must be understood to avoid severe personal injury.



CAUTIONS - show conditions that will damage equipment and/or structure.

Notes - are reminders of required procedures.

GENERAL SAFETY RULES:

- For multiple hazards, read and understand the safety instructions before installing, operating, repairing, maintaining, changing accessories on, or working near the assembly power tool for non-threaded mechanical fasteners.
- Only qualified and trained operators shall install, adjust or use the assembly power tool for non threaded mechanical fasteners.
- Do not modify this assembly power tool for non-threaded mechanical fasteners. Modifications can reduce effectiveness of safety measures and increase the risks to the operator.
- Do not discard safety instructions; give them to the operator.
- Do not use assembly power tool for non-threaded mechanical fasteners if it has been damaged.
- Tools shall be inspected monthly to verify all ratings and markings required are legible. The employer/user shall contact the manufacturer to obtain replacement marking labels when necessary.

ADDITIONAL SAFETY RULES FOR PNEUDRAULIC POWER TOOLS:

- Air under pressure can cause severe injury.
- Always shut off air supply, drain hose of air pressure and disconnect tool from air supply when not in use, before changing accessories or when making repairs.
- Never direct air at yourself or anyone else.
- Whipping hoses can cause severe injury. Always check for damage or loose hoses and fittings.
- Cold air shall be directed away from hands.
- Whenever universal twist couplings (claw couplings) are used, lock pins shall be installed and whip check safety cables shall be used to safeguard against possible hose-to-tool or hose-to-hose connection failure.
- Do not exceed the maximum air pressure stated on the tool or manual.
- Never carry an air tool by the hose.

PROJECTILE HAZARDS:

- Disconnect the tool from the energy source when changing inserted tools/nose assemblies or accessories.
- Be aware that failure of the workpiece, accessories, or the inserted tool/nose assembly itself can generate high-velocity projectiles.
- Always wear impact resistant eye protection during operation of the tool.
- Ensure that the workpiece is securely fixed.
- Check that the means of protection from ejection of fastener and/or stem is in place and operative (such as the deflector, pintail collection bottle or catcher bag).
- Forcible ejection of the mandrel from the front of the nose assembly is possible.

HYDRAULIC PUMPS:

- The user must be a qualified operator familiar with the correct operation, maintenance and use of pumps. Lack of knowledge in any of these areas can lead to personal injury.
- Do not exceed rated capacity of the pump or any equipment in the or attached to the system.
- Never attempt to lift a load weighing more than the capacity of the output device.
- Do not subject pump and its components to shock loads.
- Burst hazard exists if hose or connection pressure exceeds rated pressure.
- Inspect ALL components and connections before each use. Do not use if damaged or altered or in poor condition. Do not operate with bent or damaged threads or couplers.
- Never hold or stand directly in line with any hydraulic connections while pressurizing.
- ALWAYS use gauge or other load measuring instrument to verify load.
- Never attempt to disconnect hydraulic connections under pressure. Release all lines before disconnecting hoses.
- Use of incorrect power source will damage the motor and void your warranty.
- Do not use an ungrounded (two prong) extension cord.
- Do not install, remove or rewire the motor with power supplied. Only a trained qualified technician can service the motor.

OPERATING HAZARDS:

- Use of tool can expose the operator's hands to hazards, including crushing, impacts, cuts, abrasions and heat. Wear suitable gloves to protect hands.
- Operators and maintenance personnel shall be physically able to handle the bulk, weight and power of the tool.
- Hold the tool correctly; be ready to counteract normal or sudden movements and have both hands available.
- Maintain a balanced body position and secure footing.
- Release the start-and-stop device in the case of interruption of energy supply.
- Use only lubricants recommended by the manufacturer.
- Avoid unsuitable postures as it is likely for these positions not to allow counteracting of normal or unexpected movement of the tool.
- If the tool is fixed to a suspension device, make sure that fixation is secure.
- Beware of the risk of crushing or pinching if nose equipment is not fitted.
- Due to the tool weight, it is recommended safety shoes be worn during operation.
- It is recommended tool be operated not more than 50 out of every 60 minutes, where prolonged use is expected.

REPETITIVE MOTIONS HAZARDS:

- When using the tool, the operator can experience discomfort in the hands, arms, shoulders, neck or other parts of the body.
- While using the tool, the operator should adopt a comfortable posture while maintaining a secure footing and avoiding awkward or off balanced postures. The operator should change posture during extended tasks; this can help avoid discomfort and fatigue.
- If the operator experiences symptoms such as persistent or recurring discomfort, pain, throbbing, aching, tingling, numbness, burning sensations or stiffness, these warning signs should not be ignored. The operator should tell the employer and consult a qualified health professional.

ACCESSORY HAZARDS:

- Disconnect tool from energy supply before changing the nose assembly or accessory.
- Use only sizes and types of accessories approved by the manufacturer. Do not use other types or sizes of accessories.

WORKPLACE HAZARDS:

- Slips, trips and falls are major causes of workplace injury. Be aware of slippery surfaces caused by use of tool and also of trip hazards caused by the air line or hydraulic hose.
- Proceed with care in unfamiliar surroundings. There could be hidden hazards, such as electricity or other utility lines.
- The tool is not intended for use in potentially explosive atmospheres and is not insulated against contact with electrical power.
- Ensure that there are no electrical cables, gas pipes, etc., which can cause a hazard if damaged by the tool.

NOISE HAZARDS:

- Exposure to high noise levels can cause permanent, disabling hearing loss and other problems, such as tinnitus (ringing, buzzing, whistling or humming in the ears). Therefore, risk assessment and the implementation of appropriate controls for these hazards are essential.
- Appropriate controls to reduce the risk may include actions such as damping materials to prevent workpieces from "ringing".
- Always use hearing protection.
- Operate and maintain the assembly power tool for non-threaded mechanical fasteners as recommended in the instruction handbook, to prevent an unnecessary increase in the noise level.
- Select, maintain and replace the consumable/inserted tool as recommended in the instruction handbook, to prevent an unnecessary increase in noise.
- If the power tool has a silencer, always ensure that it is in place and in good working order when the power tool is being operated.

VIBRATION HAZARDS:

- Exposure to vibration can cause disabling damage to the nerves and blood supply of the hands and arms.
- Wear warm clothing when working in cold conditions and keep your hands warm and dry.
- If you experience numbness, tingling, pain or whitening of the skin in your fingers or hands, stop using the assembly power tool for non-threaded mechanical fasteners, tell your employer and consult a physician.
- Support the weight of the tool in a stand, tensioner or balancer, because a lighter grip can then be used to support the tool.

HYDRAULIC HOSES & FLUID TRANSMISSION LINES:

- Avoid short runs of straight line tubing. Straight line runs do not provide for expansion and contraction due to pressure and/or temperature changes.
- Reduce stress in tube lines. Long tubing runs should be supported by brackets or clips. Before operating the pump, tighten all hose connections with proper tools. Do not overtighten. Connections should only be tightened securely and leak-free. Over tightening can cause premature thread failure or high pressure fittings to burst.
- Shut off pump and release pressure. Never attempt to grasp a leaking pressurized hoses with your hands. The force of escaping hydraulic oil can inflict injury.
- Do not subject the hose to potential hazards such as fire, sharp objects, extreme heat or cold or heavy impact.
- Do not allow the hose to kink, twist, curl, crush, cut or bend so tightly that the fluid flow within the hose is blocked or reduced. Periodically inspect hoses for wear.
- Do not pull, position or move setup by the hoses.
- Hose material and coupler seals must be compatible with hydraulic oil used. Hoses also must not come in contact with corrosive materials such as battery acid, creosote-impregnated objects and wet paint. never paint a coupler or hose. Failure to heed these warning may result in personal injury and/or property damage.

PRINCIPLE OF OPERATION



When the actuator is depressed, power is supplied to the solenoid shifting the directional valve. It then puts power to the motor starter. The unit then sends hydraulic oil to the pull side of the installation tool moving the piston to the rear positions. The internal components of the attached nose assembly are also moving with the piston to start the fastener installation. When the fastener installation is complete, the actuator is released.

When the actuator is released, the circuit will supply power to the return solenoid, shifting the directional valve. The unit then sends hydraulic oil to the return side of the tool until the return pressure switch is satisfied which then shuts the motor off until the next cycle.

CAUTION: Minimum operating hydraulic oil temperature 0° (18°C). Maximum oil temperature is 176° F (80°C). Powerunit should never be run consistently with oil temperatures above 180° F (82°C) as this will cause failure to the pump. If oil is running too hot, a 5 gallon or 10 gallon reservoir may be purchased separately, this will help dissipate the heat from the oil.

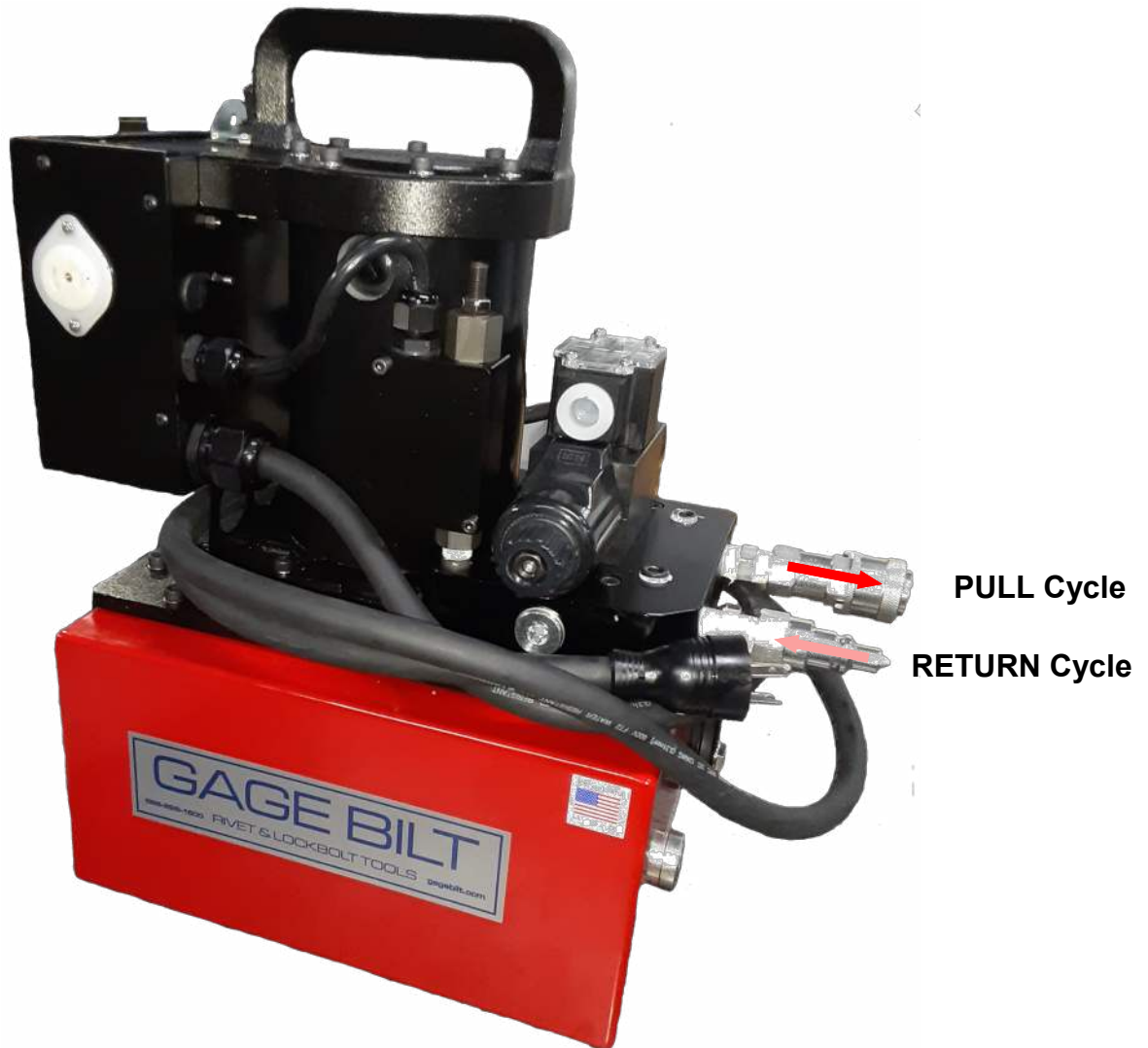



-  Pressurized Oil
-  Unpressurized Oil

Image may not reflect actual tool.



- ⚠ WARNING:** Only qualified and trained operators shall install, adjust or use the assembly power tool for non-threaded mechanical fasteners.
- ⚠ WARNING:** Operator **MUST** read and understand all warnings and cautions.
- ⚠ WARNING:** It is required that eye protection, hearing protection and safety boots be worn at all times while handling this equipment.
- ⚠ WARNING:** The users or the user's employer must assess specific risks that could be present before each use based on their application.
 - *Ensure there is adequate clearance for tool and operator's hands before proceeding. Keep fingers clear of any moving parts. Keep fingers clear from fasteners and installed materials. Severe personal injury may result.*
 - *Verify the air lines and/or hydraulic hoses are not a trip hazard.*
 - *Ensure that there are no electrical cables, gas pipes, etc., which can cause a hazard if damaged by the tool.*
 - *Verify that hydraulic hose fittings and couplings, air and electrical connections are secure before each use.*
- ⚠ WARNING:** Do not carry from hoses.
- ⚠ WARNING:** Do not use in explosive atmosphere.
- ⚠ WARNING:** Ensure air hose is securely connected to avoid possible hose whipping.
- ⚠ WARNING:** Always disconnect air supply, where applicable, when tool is not in use to prevent accidental start-up.
- ⚠ WARNING:** Do not operate when recommended pressures are exceeded as it could cause severe personal injury and or damage the equipment.
- ⚠ WARNING:** Use only Gage Bilt hydraulic hoses and couplings, or equivalent, rated for 10,000 psi. (689.5 bar) working pressure.
- ⚠ WARNING:** Proper PULL and RETURN pressures are important for proper function of installation tools. Severe personal injury or damage to equipment may occur without correct pressures. Pressure gage assembly (942280) is available for checking these pressures. Set pressures per instructions furnished with applicable hydraulic installation tool instruction manual. See "setting pressures."
- ⚠ WARNING:** Hydraulic powerunits that deliver high pressure for both PULL & RETURN and are not equipped with relief valves are specifically not recommended, and may be dangerous.
- ⚠ WARNING:** Gage Bilt does not recommend making adjustments without using the pressure gage assembly (942280).
- ⚠ CAUTION:** Do not use beyond the design intent.
- ⚠ CAUTION:** The pump is shipped without oil in the reservoir. Do not operate the pump without sufficient oil in the reservoir, instant damage to the pump will occur if ignored.
- ⚠ CAUTION:** Guard against exceeding above 60°C (140°F). Various commercial thermometers are available to monitor oil temperature in the reservoir. Continuous operation with reservoir oil temperatures in excess of 60°C (140°F) can cause permanent damage to the pump.
- ⚠ CAUTION:** Keep dirt and other foreign matter out of hydraulic systems of tools, hoses, couplers and powerunit. Do not let hose fittings and couplers contact a dirty floor or unclean working surface. Foreign matter in hydraulic oil may cause the tool and the powerunits valves to malfunction.

It is recommended that, prior to each use, an inspection be done by qualified personnel and that any missing or damaged parts be replaced with factory authorized parts only. Any valve that appears to be damaged in any way, is worn, leaking or operating abnormally must be removed from service immediately until such time as repairs can be made.

Avoid the use of extension cords. If necessary, for extension cords lengths up to 25 ft (7.6 m), use SJT-14X3 or heavier. For cords up to 50 ft. (15.2 m), use SJT-12X3 or heavier. For extension cord lengths up to 100 ft. (30.4 m), use SJT-10X3 or heavier. NEVER use a 3 prong adapter. To avoid electrocution hazard connect ONLY to a properly grounded source. Connect to GFI outlet ONLY.

1. Clean area around the air vent seat (oil reservoir cap) (946021) before filling reservoir with hydraulic oil. **Note:** Unit is shipped **without** oil.
2. Remove air vent seat (oil reservoir cap) (946021).
3. Using a clean funnel fill reservoir with DEXRON® III or equivalent to 2.00 inches (50.8 mm) from the bottom of the reservoir cover.
4. Replace air vent seat (oil reservoir cap) (946021).
5. Connect the PULL pressure hose to the PULL pressure output coupler. **Note:** Couplings must be clean and free of dirt.
6. Connect the RETURN pressure hose to the RETURN pressure output coupler. **Note:** Couplings must be clean and free of dirt.
7. Check tool manual for recommended hydraulic pressures. Set pressures accordingly using pressure setting gage assembly (942280) (sold separately). See page 9 & 10 of this manual.
8. Plug the control cord from the tool into the two pronged socket on the Powerunit.
9. Turn power on and cycle the pump (with tool attached) several times while examining tool and pump for any hydraulic leaks. Re-check the oil level in the reservoir with the tool in the (RETURN) position.
10. Turn pump off. Disconnect the GB947 Powerunit from the power supply. Installation tool is ready for user to attach an applicable nose assembly. **Note:** See tool manual for complete list of nose assemblies. See nose assembly data sheet for installation.

HOW TO SET-UP THE GB947



⚠ WARNING: Ensure both PULL and RETURN pressures are suited to match the equipment being used.

⚠ CAUTION: The GB947 Powerunit is designed for high speed pressures for only a short period. Complete check as soon as possible.

The pressure gage assembly (942280) (sold separately) set-up is used to check the pressure settings for both the PULL and RETURN pressures. Personnel servicing the GB947 Powerunit should be give access to the gage set-up.

Replacement couplers are available in a set, (Hydraulic coupling assembly (585037), which includes one hydraulic coupler-female (585038) and one hydraulic coupler-male (585047).

PARTS LIST-GAGE SET-UP

	Part Number	Qty.	Description
Replacement O’ring (404438) for the coupler body-female (585038).	407299	1	Gage - 10,000 psi
	403912	1	Reducer
Replacement back-up ring (401102) for the coupler body-female (585038).	*585047	1	Hydraulic Coupler-male
	403683	4	Pipe Nipple
Replacement control cord connectors are available in a set, connector assembly (585035), which includes one connector- female (585044) and one connector male (585045).	403368	2	Shut-off Valve
	403911	1	Tee
	*585038	1	Hydraulic Coupler-female
	* 585038 & 585047 are available in sets as Hydraulic Coupling Assembly (585037)		

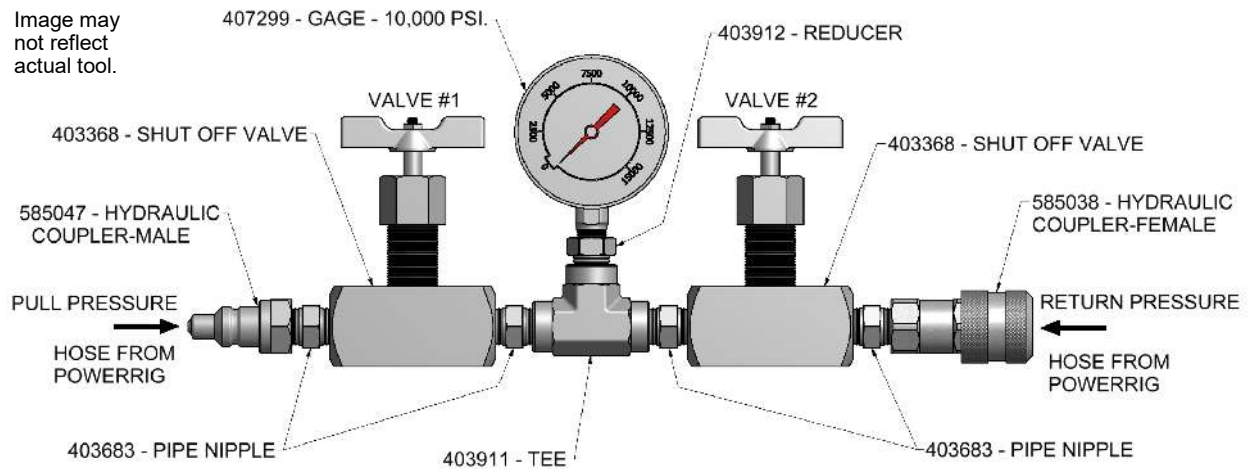

HOW TO SET-UP THE GB947



- ⚠ WARNING:** Hydraulic pressure must be adjusted based on the hydraulic tool. See tool manual for correct pressure requirements.
- ⚠ WARNING:** Do not operate when recommended pressures are exceeded as it could cause severe personal injury and or damage the equipment.
- ⚠ WARNING:** Proper PULL and RETURN pressures are important for proper function of installation tools. Severe personal injury or damage to equipment may occur without correct pressures. Pressure gage assembly (942280) is available for checking these pressures. Set pressures per instructions furnished with applicable hydraulic installation tool instruction manual.

ADJUSTING AND SETTING OUTPUT PRESSURES

PULL Pressure Procedure:

1. Turn adjusting pull pressure knob clockwise, to increase PULL pressure.
2. Turn adjusting pull pressure knob counterclockwise, to decrease PULL pressure.
3. Tighten jam nut when desired pressure is achieved.



Loosen/Tighten Nut

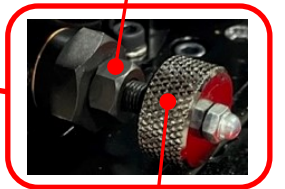

Pull Pressure Knob

RETURN Pressure Procedure:

1. Loosen adjusting lock nut.
2. Using a hex key, turn pressure screw clockwise to increase RETURN pressure.
3. Using a hex key, turn pressure screw counter clockwise to decrease RETURN pressure.
4. Once desired pressure is achieved tighten adjusting jam nut.

Note: Adjust pressure by turning pressure screw at 1/8 (45°) turn increments. See diagram to right.

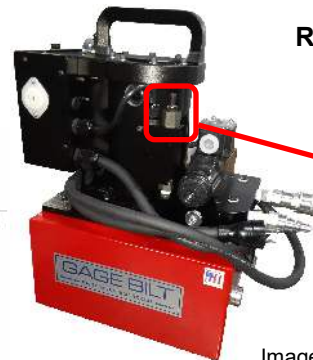
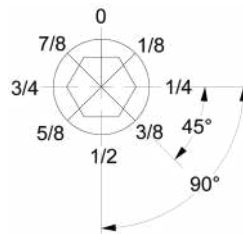

Return Pressure Screw

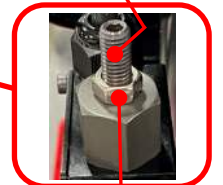

Loosen/Tighten Nut

Images may not reflect actual tool.

CHECKING PULL PRESSURE

NOTE: The GB947 Powerunit should be checked, as required by the installation tool manual, at first time start-up, when troubleshooting and after overhauling directional valve or pump. For assisting in this procedure use Pressure Gage Assembly (942280). The Pressure Gage Assembly (942280) is used to check the pressure settings for PULL and RETURN pressures. Personnel servicing the GB947 Powerunit should be given access to this gauge set-up. (See page 9 for pressure gage assembly (942280).

The GB947 Powerunit is designed for high pressures for only a short period. Complete this check as quickly as possible.

1. Disconnect tool from GB947 power unit.
2. Connect valve #1 of pressure gage to pull side of GB947 power unit.
3. Open valve #1 (counter clockwise) and close valve #2 (clockwise).
4. Plug the air actuator from the installation tool into power unit.
5. Cycle tool to start the motor and directing hydraulic oil to pull side of powerunit. Read gage pressure.

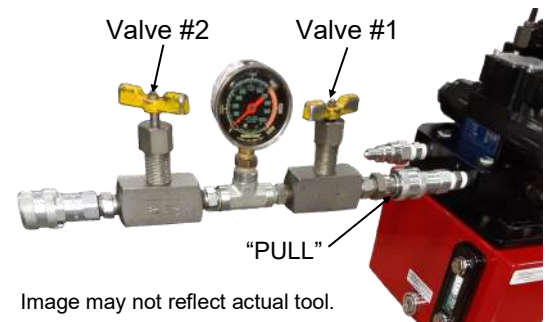

Image may not reflect actual tool.

CHECKING RETURN PRESSURE

1. Disconnect tool from GB947 power unit.
2. Connect valve #2 of pressure gage to RETURN side of GB947 power unit.
3. Open valve #2 (counter clockwise) and close valve #1 (clockwise).
4. Plug the installation tool into power unit.
5. Cycle tool to start the motor, releasing the actuator will direct hydraulic oil to return side of power unit, read gage pressure at highest point.

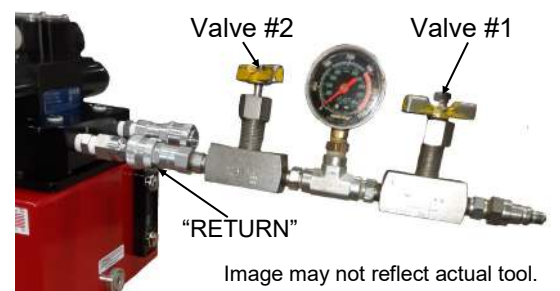

Image may not reflect actual tool.

HOW TO SET-UP THE GB947



FILLING THE RESERVOIR

1. Make sure electric motor is OFF.
2. Depressurize and disconnect hydraulic hoses from application.
3. Remove air vent seat (reservoir cap) (946021) on the top plate of the reservoir.
4. Use a funnel to fill reservoir to about 2.00" (50.8 mm) from top of reservoir plate.
5. Wipe up any spilled oil and reinstall air vent seat (reservoir cap) (946021).

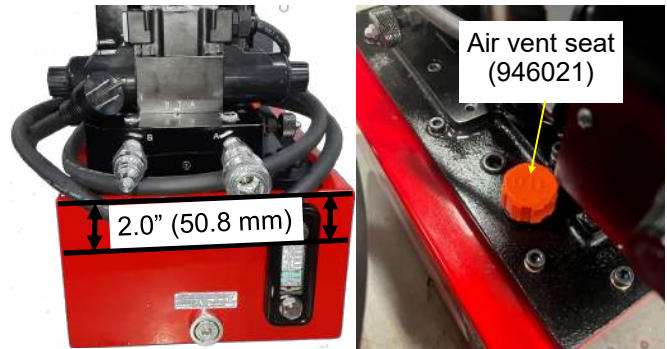

DRAINING AND FLUSHING THE RESERVOIR

1. For best results, change oil every 300 hours or once a year, depending on use or environmental conditions.
2. Depressurize and disconnect hydraulic hoses from application.
3. Ensure motor is off and power is disconnected then place the Powerunit on a flat stable surface.
4. Provide a suitable container to hold used oil. Using a hex key, unthread and remove oil drain plug assembly (946031).
5. Remove air vent seat (reservoir cap) (946021) on the top plate of the reservoir.
6. Tilt the pump and let used oil completely drain from reservoir into oil container.
7. Use a funnel to re-fill reservoir to about 2.00" (50.8 mm) from top of reservoir plate.
8. Wipe up any spilled oil from all surfaces including drain plug assembly (946031). Reinstall vent seat (946021).
9. Re-thread and tighten oil drain plug assembly (946031) to Powerunit.
10. Dispose of all used oil in accordance with the manufacturers safety datasheet.



Note: Clean oil filter screen periodically with nonflammable solvent, then blow dry before reassembling back onto the pump.

RESERVOIR TEMPERATURE CONTROL CAUTION

Guard against exceeding above 50°C (122°F). Various commercial thermometers are available to monitor oil temperature in the reservoir. Continuous operation with reservoir oil temperatures in excess of 50°C (122°F) can cause permanent damage to the pump.

- a. At oil temperatures above 60°C (140°F) HA-57 oil tends to thin and lose its ability to provide an adequate oil film in the ball bearings and between various precision sliding surfaces in the pump mechanism. Furthermore, the oil additives tend to break down at continuous operations above 60°C (140°F) reducing effectiveness of sealing materials.
- b. Should over heating occur: Consider replacing the 2-1/2 gallon reservoir with a five gallon reservoir which has a higher heat dissipating capacity. In general, a five gallon reservoir will take twice as long to reach 60°C (140°F) as a 2-1/2 gallon reservoir.

Hydraulic Oil: Standard hydraulic oil with a viscosity rating of 300 SUS @ 100 deg. F. and 50 SUS @ 210 deg. F.

Hydraulic Oil is not supplied by Gage Bilt. Use automatic transmissions oil, DEXRON III®, or equivalent. Fire resistant hydraulic oil must be used to comply with OSHA regulation 1926.302 paragraph (d): "the fluid used in hydraulic power tools shall be fire resistant fluid approved under Schedule 30 of the US Bureau of Mines, Department of Interior, and shall retain its operating characteristics at the most extreme temperatures to which is will be exposed." Fluid viscosity 300 SUS @ 100°F and 50 SUS @ 210° F is recommended for ambient temperatures 0 to 130° F.

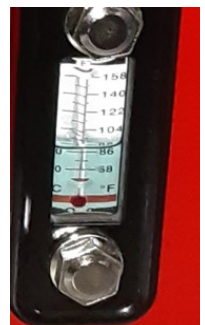

Images may not reflect actual tool.

DAILY MAINTENANCE



- ⚠ WARNING:** Pump must be maintained in a safe working condition at all times and examined on a daily basis for damage or wear. Any repair must be done by qualified personnel trained on Gage Bilt procedures.
- ⚠ WARNING:** Excessive contact with hydraulic oil and lubricants must be avoided.
- ⚠ WARNING:** Maintenance personnel **MUST** read and understand all warnings and cautions.
- ⚠ WARNING:** Disconnect pump from its power source before performing maintenance, cleaning or when replacing worn or damaged components. Severe personal injury may occur if power source is not disconnected.
- ⚠ WARNING:** Read Safety Data Sheet documents for all applicable materials.
- ⚠ WARNING:** To avoid crushing and related injuries, NEVER work on, around, or under a lifted load before it is properly supported by the appropriate mechanical means. Never rely on hydraulic pressure alone to support load.
- ⚠ WARNING:** Avoid the use of extension cords. If necessary, for extension cords lengths up to 25 ft (7.6 m), use SJT-14X3 or heavier. For cords up to 50 ft. (15.2 m), use SJT-12X3 or heavier. For extension cord lengths up to 100 ft. (30.4 m), use SJT-10X3 or heavier. NEVER use a 3 prong adapter. To avoid electrocution hazard connect ONLY to a properly grounded source. Connect to GFI outlet ONLY.

Note:

- Dispose of hydraulic oil in accordance with manufacture safety datasheet.
- All tool materials are recyclable except rubber o'rings, seals and wipers.
- To ensure smooth operation, bleed air from the system by fully advancing and retracting the cylinder several times.
- Avoid the use of extension cords if possible. (See [warning](#) above).

The performance of any tool depends upon good maintenance practices. Following these minimal requirements daily will extend the life of your pump. Scheduled inspections to detect and correct minor problems are part of an effective preventative maintenance program.

Owners and operators of this equipment shall be aware that the use and subsequent repair of this equipment may require special training and knowledge. Proper care by operators is necessary in maintaining full productivity and reducing downtime.

- * Keep areas around the pump obstruction free in order to provide good air flow around the pump and motor. Keep pump and motor clean.
- * Inspect hoses and couplings for wear, damage and leaks. (Replace/Repair if necessary). Couplings must be clean and free of dirt.
- * Verify that hydraulic hose fittings, couplings and electrical connections are secure. Tighten, Replace or Repair if necessary.
- * Check hydraulic oil every 40 hours of operation and add/replace hydraulic oil based on recommendations below.
- * Keep hydraulic system and exterior surface clean.
- * Any unusual differences noted, would suggest this course of action before further operation: Drain and discard used oil. Refill with new oil.
- * Check electrical cord for damage or wear before and after each use. Replace if necessary.
- * Do not operate this powerunit if line voltage varies $\pm 5\%$ from recommended specifications (120V/230V).

SEE TROUBLESHOOTING (PGS. 14 - 15) FOR FURTHER GUIDANCE.

WEEKLY MAINTENANCE

Keep the hydraulic system filled with hydraulic oil. We recommend DEXRON® III or equivalent. Use only recommended oil as other hydraulic oil may result in pump failure and will void your warranty.

- * Changing hydraulic oil: Change oil every 300 hours or once a year depending on use and environmental conditions. When changing oil, clean filter screen with nonflammable solvent, blow dry before reassembling. (Note: Replace filter screen if damaged).
 - a) Remove drain plug, tilt the pump, then pour used oil into a sealable container.
 - b) Clean area around vent cap hole. Fill hydraulic oil to about 2" (50.8 mm) from top of reservoir plate, then reinstall vent cap. Wipe area clean (if spillage occurs).
 - Note:** Avoid getting particles, dust or debris into clean oil once filled. Damage to pump could occur.
 - c) Dispose of hydraulic oil in accordance with the material safety datasheet.
- * The following conditions would warrant more frequent hydraulic oil changes:
 - a) Very dusty environment where dust enters reservoir.
 - b) Hourly operations near 60°C (140°F), evidence of oxidation and formation of gum, sludge and/or varnish.
 - c) Exposure to frequent extreme temperature changes and high humidity resulting in excessive condensation in the reservoir while in storage.



CAUTION: Springs on the carbon brushes (947141) will push on the carbon brush seats (947142). Hold the brush seats (947142) as they are loosened and removed.

INSPECTING MOTOR CARBON BRUSHES (EVERY 3 MONTHS OR 300 HOURS)

Checking the motor carbon brushes (947141) consistently helps to prevent premature failure of the armature. See pg. 21 for parts breakdown. To help prevent premature failure of the armature, inspect the brushes EVERY 3 MONTHS OR 300 HOURS (depending on use):

To inspect carbon brushes (947141) follow these steps:

1. Using a large flat head screw driver, unscrew and remove the 2X carbon brush seat (947142). See **caution** above.
2. Remove the 2X carbon brushes (947141). See **caution** above.
3. Clean copper commutators on the armature.
4. Clean out the spaces between connections. If commutator is damaged or worn, replace armature.
5. Measure the length of the carbon brush (947141), and replace both brushes if either one is .118 inch (3 mm) or less in length.
6. Re-install brush assemblies and brush seats. Using a large flat head screw driver, tighten brush seats. See **caution** above.

REPLACING MOTOR CARBON BRUSHES

To help prevent premature failure of the armature, replace the carbon brushes: (IF BRUSH MEASURES .118" (3 mm) LONG OR LESS):

1. Unthread and remove the carbon brush seat (947142) and carbon brush (947141). See **caution** above.

Note: The brush assemblies must be replaced if they measure .118" (3 mm) long or less.
New carbon brushes will measure between .749" (19 mm) and .867" (22 mm) long.

2. Re-Install new brush assemblies (947141) with the carbon brush seats (947142) and tighten securely. See **caution** above.

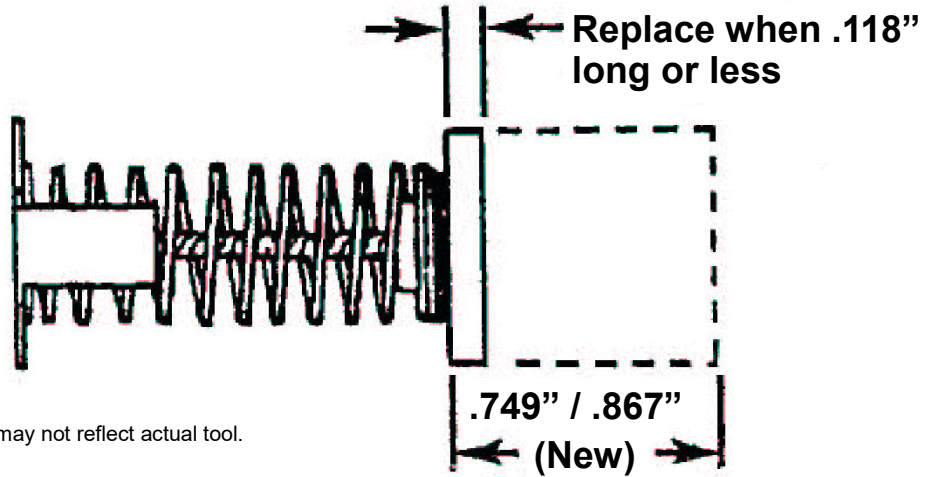
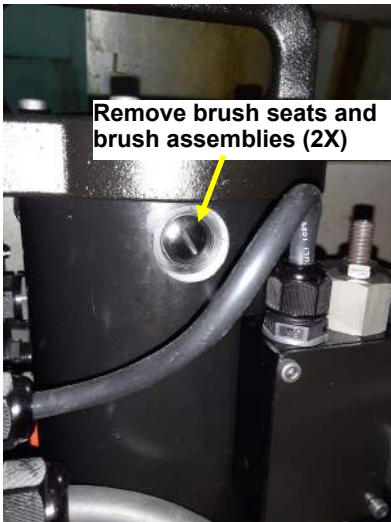

Images may not reflect actual tool.

HYDRAULIC THREAD PREPARATION

IMPORTANT: Be sure to use thread sealant on all hydraulic fittings, Loctite® 545 or equivalent or a non-hardening Teflon® thread compound such as Slic-tite®. Tighten until fitting feels snug and then continue to tighten 1/2 to 1 full turn. **CAUTION:** Over tightening can easily distort the threads. **DO NOT USE TEFLON® TAPE.** **CAUTION:** Teflon® tape is an excellent thread sealer, however, if it is not properly applied, pieces of Teflon® may enter the hydraulic system and cause a malfunction or damage.

STORAGE

1. When not in use, depressurize and disconnect hydraulic hoses from application.
2. Thoroughly wipe clean.
3. Store in clean, dry environment. Avoid temperature extremes.
4. For transportation or long term storage, shield pump with a protective cover.



Providing all maintenance conditions have been met, follow this systematic approach to diagnosis.

1. MOTOR WILL NOT START.

- a) No power or wrong voltage. Check the power supply & voltage.
- b) Damaged power cord. Contact customer service.
- c) Tripped circuit breaker. Ensure electrical supply is adequate.
- d) Loose or faulty wiring. Contact customer service.

2. ERRATIC CYLINDER ACTION.

- a) External leak. Tighten all connections.
- b) Internal hydraulic leak. Contact service center.

3. PUMP FAILS TO MAINTAIN PRESSURE.

- a) External leak. Tighten all connections.
- b) Internal hydraulic leak. Contact service center.
- c) Pump or valve malfunction. Contact service center.

4. CYLINDER EXTENDS PARTIALLY.

- a) Hydraulic oil level too low in pump. Fill and bleed the system.
- b) Load is above the capacity of the system. Use the correct equipment.
- c) Cylinder is sticking or binding. Contact service center.

5. CYLINDER MOVES SLOWER THAN NORMAL.

- a) Loose connection or coupler. Tighten.
- b) Restricted hydraulic line or fitting/ Clean and replace if damaged.
- c) Pump not working correctly. Check pump operating instructions.
- d) Cylinder seals leaking. Replace cylinder.

6. CYLINDER LEAKS HYDRAULIC OIL.

- a) Worn or damaged seals. Replace cylinder.

7. CYLINDER WILL NOT RETRACT OR RETRACTS SLOWER THAN NORMAL.

- a) Loose couplers. Tighten couplers.
- b) Weak or broken retraction spring. Replace cylinder.
- c) Cylinder damaged internally. Replace cylinder
- d) Pump reservoir too full. Drain hydraulic oil to correct level.

8. MOTOR CUTS OUT.

- a) Extension chord too long. Replace.
- b) Faulty motor. Replace or repair.
- c) Overheated motor trips circuit breaker. Allow motor to cool, reset circuit breaker.



9. TOOL WILL NOT CYCLE.

- a) Check the system pressure; if the pressure is zero: the control valve is releasing pressure and the problem may be in the cylinder, mechanical linkage connected to cylinder or quick-disconnect couplings. Check the cylinders for broken return springs and check couplers to ensure they are completely coupled. Occasionally couplers have to be replaced because one check does not stay open in the coupled position.
- b) Damaged or plugged quick-disconnect couplers. Replace / repair couplers.
- c) Damaged valve. Check valve operation and inspect parts. Replace if necessary.
- d) Improperly coupled hoses. Check hose assembly.
- e) Bind in tool or nose assembly. Ensure parts move freely.
- f) Pump to motor coupling damaged. Replace coupling.
- g) Hydraulic oil level is low or viscosity not proper. Replace oil or fill to within 2.00" (50.8 mm) from top of reservoir plate.
- h) Unloading valve in tool improperly installed or missing. Check tool.

10. FASTENER SWAGES BUT WON'T BREAK.

- a) Pull pressure set too low. See "Pressure Setting" section (pg. 10)
- b) Check for any external leaks. Tighten / seal all connections.
- c) Damaged cylinder. (Remove cylinder from the system to ensure that it is not leaking). Replace if leaking.
- d) Leaking pressure switch seal. Repair or replace.
- e) Check the external pressure regulator and/or the relief valve setting. Lift the pump from the reservoir but keep the filter immersed in oil. Note the pressure reading when the relief valve begins to open. If functioning normally, it should start to leak off at relief valve pressure.
- f) Inspect the pump for internal leakage. Check high pressure pump inlet or outlet ball checks. Same procedure as above, but look for leaks around the entire inner mechanism. If there are no visible leaks, the high pressure pump sub-assembly may be leaking. Remove all parts. Check the valve head assembly body for any damage to the seat area. Clean and reseal if necessary. Inspect for damage and replace if necessary, then reassemble.
- g) Sheared key. Replace.

11. TOOL WILL NOT RETURN OR PUSH NOSE ASSEMBLY OFF OF SWAGED FASTENER WHEN SWITCH IS RELEASED.

- a) RETURN pressure set too low. See "Setting or Adjusting Output Pressure" section of this manual.
- b) Damaged solenoid. Replace.
- c) Damaged / plugged quick-disconnect couplers. Replace or repair couplers.

12. MOTOR WILL NOT SHUT OFF AFTER RETURN.

- a) Return pressure is too high. "See adjusting and setting pressures".
- b) Damaged solenoid. Replace.
- c) Damaged.

13. PUMP MAKING NOISE THROUGHOUT ENTIRE CYCLE.

- a) Pump is cavitating the oil. Viscosity is too heavy or the oil level may be too low. Fill reserve to within 2" (50.8 mm) from top plate with all cylinders retracted.
- b) Filter is clogged or dirty. Clean filter.
- c) Damaged pump. Replace pump.

ELECTRIC PUMPS PARTS LIST

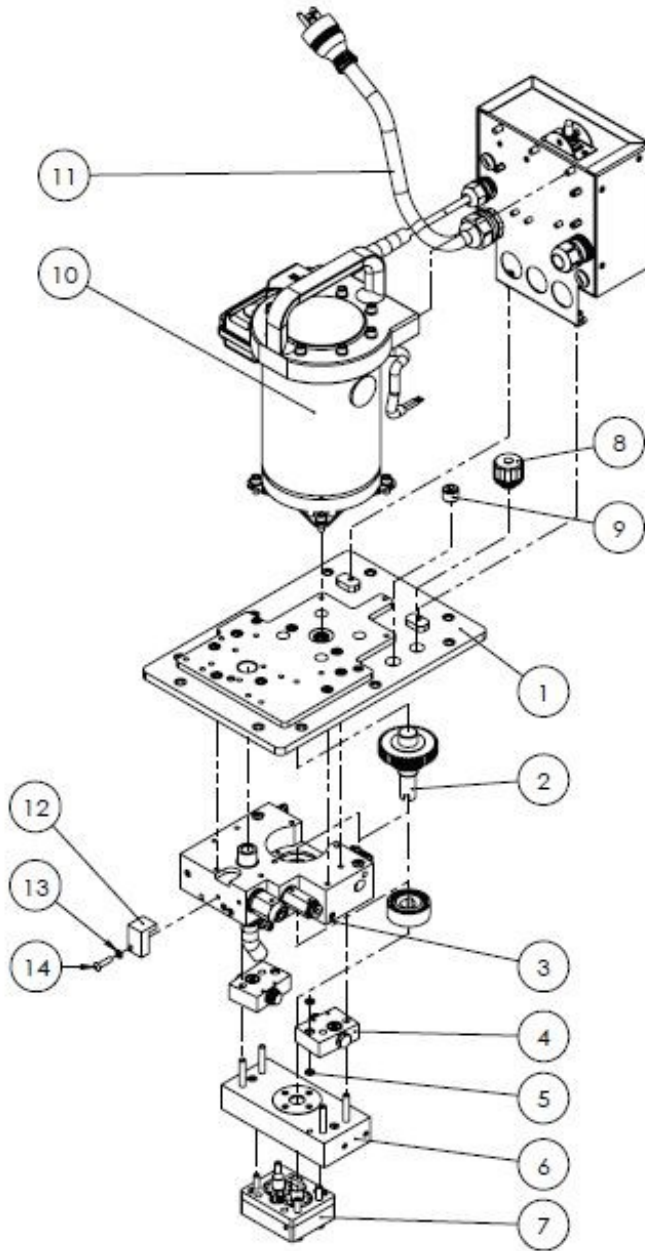

ITEM	PART NUMBER	DESCRIPTION	QTY
1	N/A	RESERVOIR COVER ASSEMBLY	1
2	947100	GEAR WHEEL SHAFT	1
3	947101	HYDRAULIC MANIFOLD BLOCK	1
4	947102	PISTON BLOCK ASSEMBLY	2
5	946019	O'RING	2
6	947103	LOWER PLATE ASSEMBLY	1
7	947104	GEAR PUMP ASSEMBLY	1
8	946021	AIR VENT SEAT	1
9	947105	PARKER HEX PLUG	1
10a	947106	MOTOR-120V, 50/60 Hz	1
10b	947107	MOTOR-230V, 50/60 Hz	1
11a	947108	OPERATION CONTROL BOARD ASSEMBLY 120 VAC	1
11b	947109	OPERATION CONTROL BOARD ASSEMBLY 230 VAC	1
12	947110	DRAIN BLOCK	1
13	947111	SPRING WASHER	1
14	947112	HEX SOCKET HEAD BOLT	1

N/A= NOT AVAILABLE AS REPLACEMENT ITEM

4/23

2.5 GALLON RESERVOIR ASSEMBLY PARTS LIST

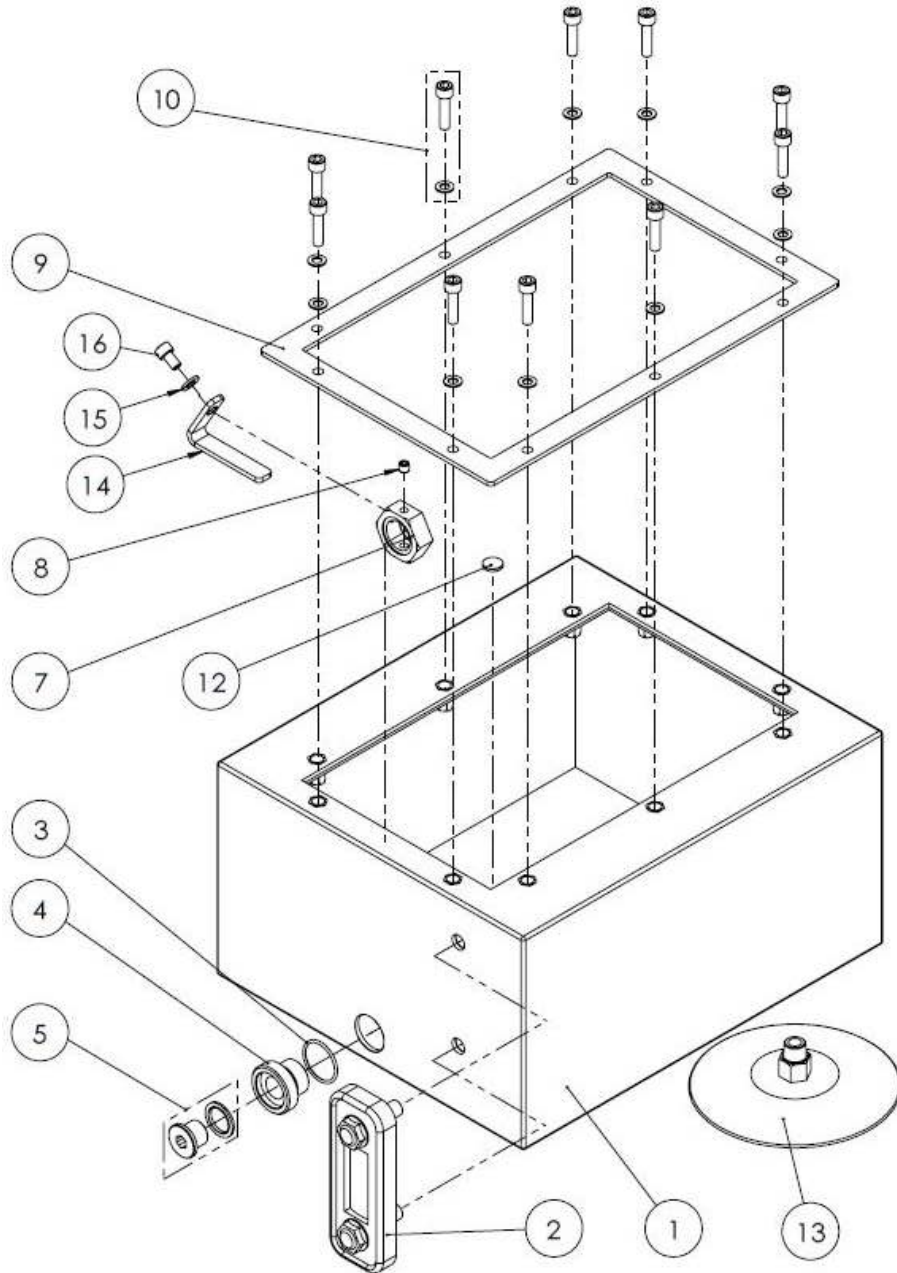

ITEM	PART NUMBER	DESCRIPTION	QTY
1	947113	RESERVOIR	1
2	947114	COLUMN LEVEL INDICATORS	1
3	947115	O'RING	1
4	947116	TANK SCREW SEAT	1
5	946031	DRAIN PLUG ASSEMBLY	1
7	947117	HEX NUT	1
8	947118	BOLT	1
9	946013	RESERVOIR GASKET	1
10	947119	HEX BOLT AND WASHER ASSEMBLY	1
12	946029	MAGNET	1
13	947120	SCREEN	1
14	947121	V-SHAPED BLANK	1
15	947122	SPRING WASHER	1
16	947123	BOLT	1

PUMP PISTON SET PARTS LIST

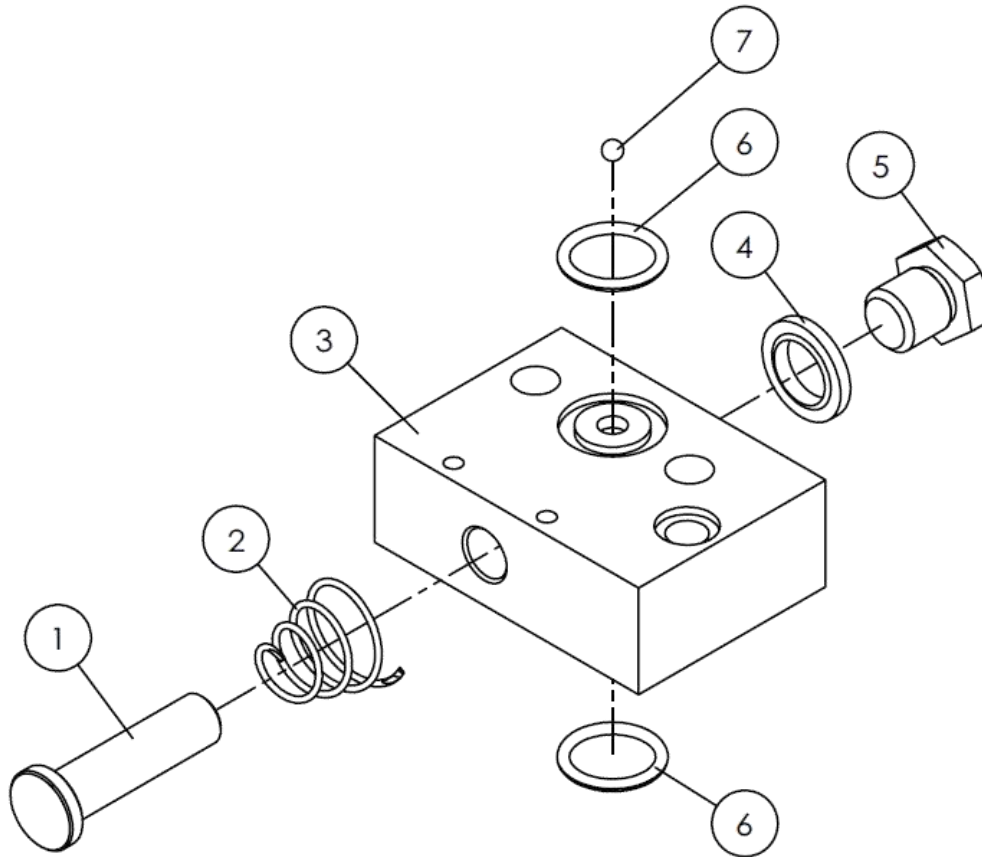

ITEM	PART NUMBER	DESCRIPTION	QTY
1	N/A	PISTON (6.8 mm dia.)	1
2	*	SPRING	1
3	N/A	PISTON BLOCK - 1.0 HP	1
4	946041	WASHER	1
5	946042	HEX HEAD PLUG	1
6	*	O-RING	2
7	*	BALL	1
**	*	O-RING	2
*	946002	REPAIR KIT	1

N/A= NOT AVAILABLE AS REPLACEMENT ITEM, * = INCLUDED WITH 946002 REPAIR KIT, ** = NOT SHOWN

4/23

MANIFOLD BLOCK ASSEMBLY PARTS LIST

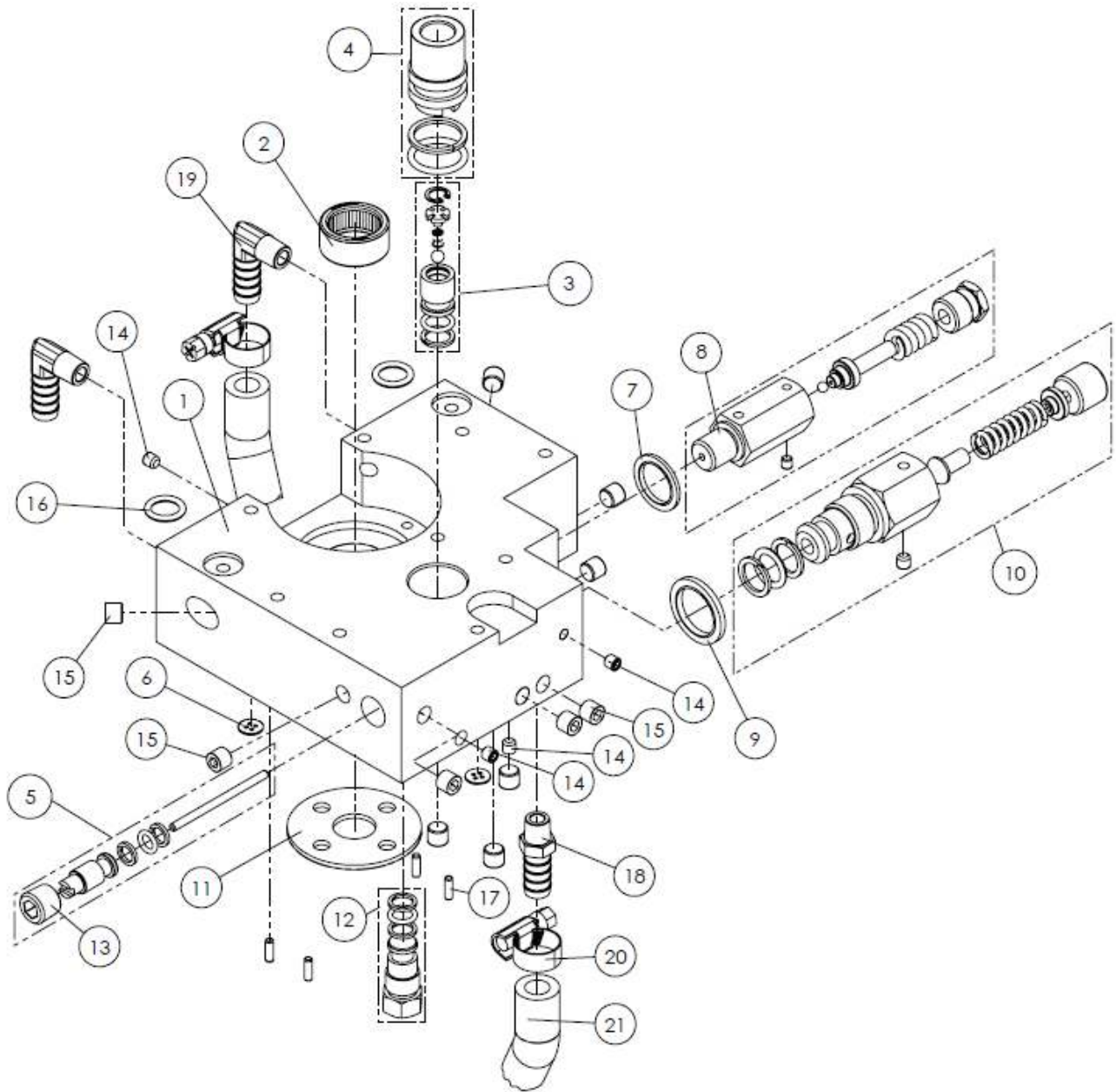

ITEM	PART NUMBER	DESCRIPTION	QTY	ITEM	PART NUMBER	DESCRIPTION	QTY
1	N/A	HYDRAULIC MANIFOLD BLOCK	1	12	947132	POLE PLUG GROUP	1
2	947124	BEARING NEEDLE	1	13	946051	HEX PLUG	1
3	947125	CHECK VALVE BASE ASSEMBLY	1	14	947133	SCREW	4
4	947126	SEAT POST	1	15	946035	HEX SOCKET PIPE PLUG	11
5	947127	STICK VALVE ASSEMBLY	1	16	947134	O'RING	2
6	946036	BALL RETAINER	2	17	946037	PIN	4
7	947128	SPECIAL WASHER	1	18	947135	MALE HOSE BARB CONNECTOR	1
8	947129	BLOCK-UNLOADING ASSEMBLY	1	19	947136	MALE HOSE BARB ELBOW	2
9	947130	SPECIAL WASHER	1	20	947137	HOSE CLAMP	2
10	947131	1ST RELIEF VALVE ASSEMBLY	1	21	947138	OIL HOSE 10.25"	1
11	946038	THRUST WASHER	1	22	947002	MANIFOLD BLOCK REPAIR KIT	1

NA= NOT AVAILABLE AS REPLACEMENT ITEM

4/23

GEAR PUMP ASSEMBLY PARTS LIST

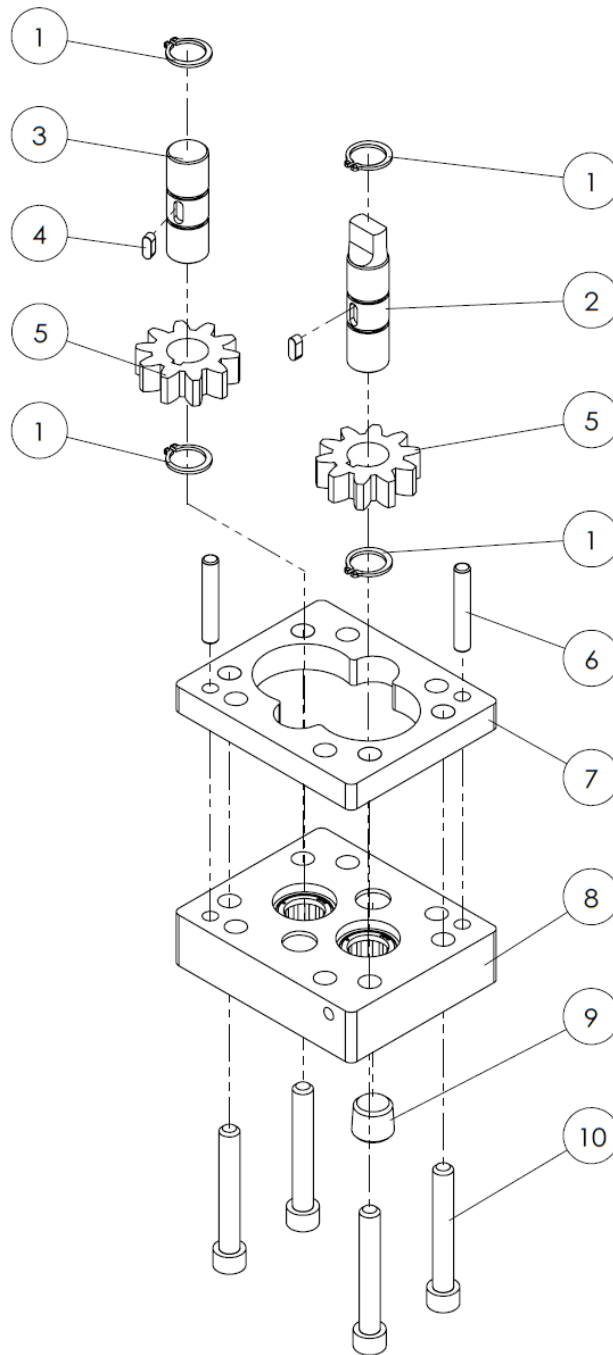

ITEM	PART NUMBER	DESCRIPTION	QTY
1	*	RETAINING RING-EXTERNAL	4
2	946046	DRIVE SHAFT-GEAR PUMP	1
3	946047	IDLER SHAFT-GEAR PUMP	1
4	*	KEY	2
5	946048	GEAR	2
6	*	PIN DOWEL	2
7	N/A	CENTER GEAR PLATE	1
8	N/A	LOWER GEAR PLATE ASSEMBLY	1
9	946051	PARKER HEX PLUG	1
10	946052	SCREW	4
*	946004	GEAR PUMP ASSEMBLY REPAIR KIT	1

N/A= NOT AVAILABLE AS REPLACEMENT ITEM, * = INCLUDED WITH 946004 GEAR PUMP ASSEMBLY REPAIR KIT

4/23

MOTOR ASSEMBLY PARTS LIST

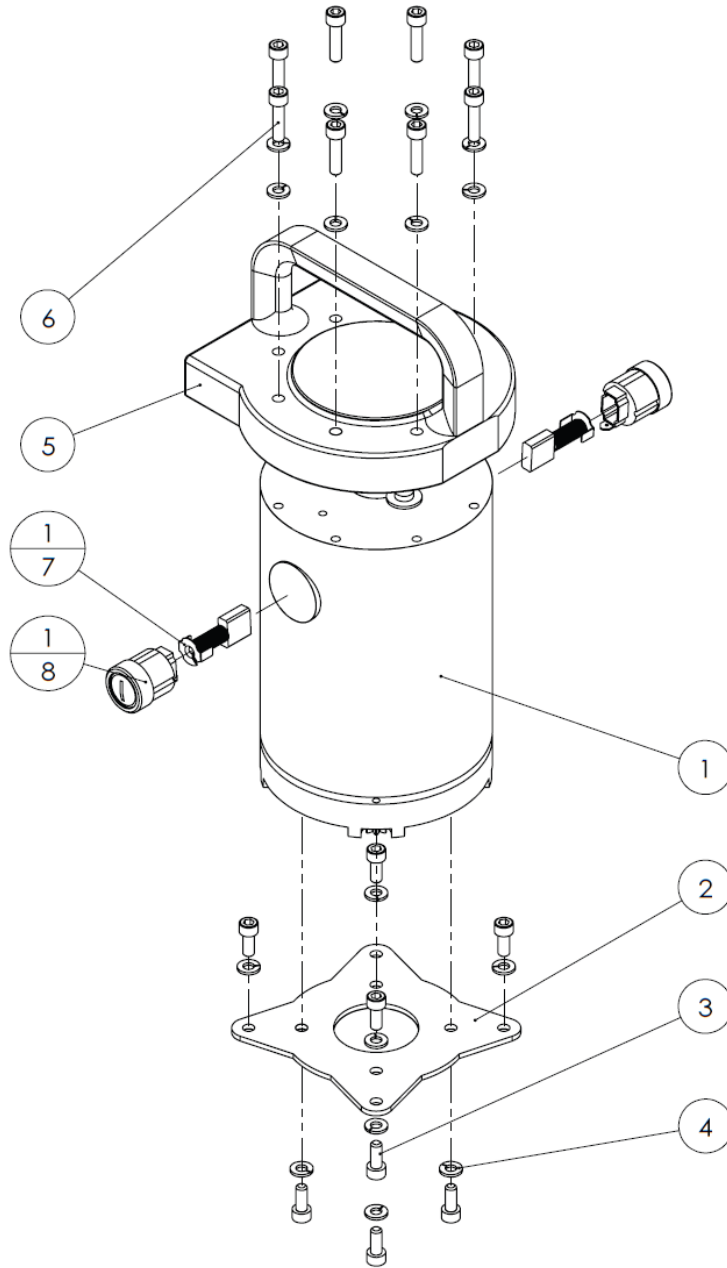

ITEM	PART NUMBER	DESCRIPTION	QTY
1a	947139	UNIVERSAL MOTOR, 120 VAC, 50/60 Hz	1
1b	947140	UNIVERSAL MOTOR, 230 VAC, 50/60 Hz	1
2	947143	FLANGE	1
3	947144	BOLT	8
4	947122	SPRING WASHER	16
5	947145	HANDLE	1
6	946022	BOLT	8
1-7	947141	CARBON BRUSH	2
1-8	947142	CARBON BRUSH SEAT	2

4/23

ENCLOSURE ASSEMBLY PARTS LIST

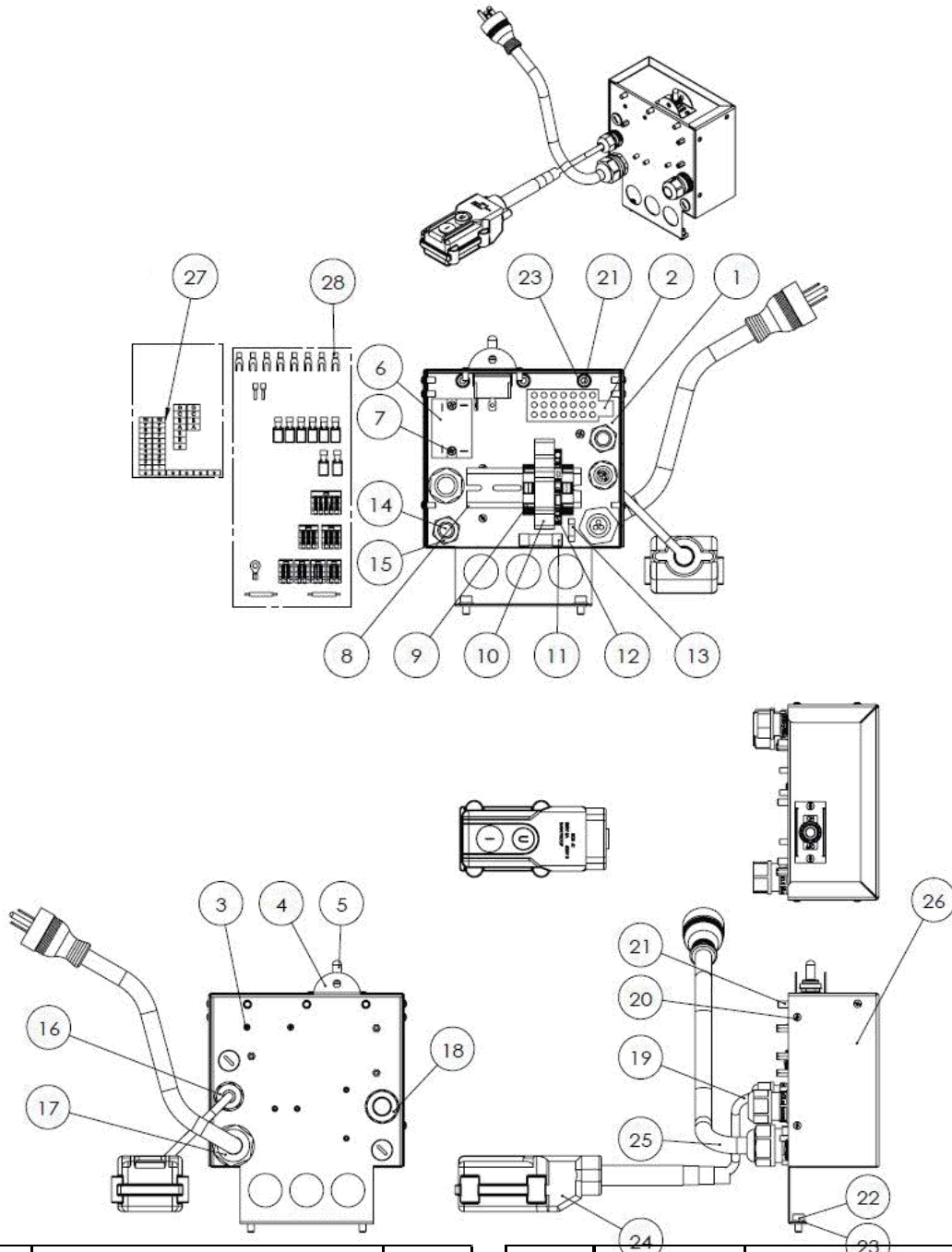

ITEM	PART NUMBER	DESCRIPTION	QTY
1	N/A	CONTROL BOARD	1
2	947146	POWER SUPPLY UNIT	1
3	947147	SCREW	2
4	N/A	SWITCH BASE	1
5	947148	ON/OFF 4P TOGGLE SWITCH	1
6	947149	POWER RELAY	1
7	947150	SCREW	3
8	N/A	CARRIER RAIL	1
9	N/A	(TS 35) END BLOCK	2
10	947151	TERMINAL (FUSE)	1
11	947152	FUSE	1
12	N/A	TERMINAL SEAT (FUSE)	1
13	947153	FUSE (TUBING)	1
14	947154	NYLON SCREW PLUGS	2
15	947155	NYLON LOCK NUTS	2

ITEM	PART NUMBER	DESCRIPTION	QTY
16	947156	CABLE GLAND	1
17	947157	CABLE GLAND	1
18	947158	CABLE GLAND	1
19	947159	POWER CORD	1
20	947160	SCREW	12
21	947161	BOLT	3
22	947123	BOLT	2
23	947122	SPRING WASHER	5
24	947162	PENDANT STATIONS	1
25	947163	POWER CORD	1
26	N/A	COVER	1
27	N/A	WIRE MARKERS ASSEMBLY	1
28	947164	CONNECTOR	1

N/A= NOT AVAILABLE AS REPLACEMENT ITEM

4/23

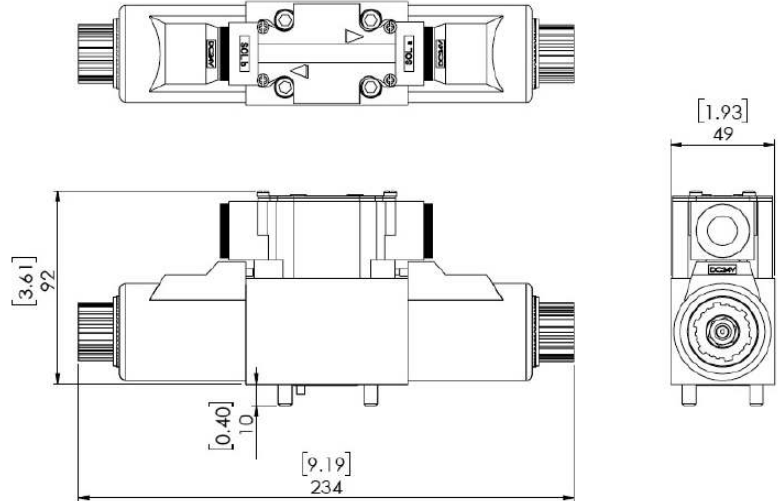
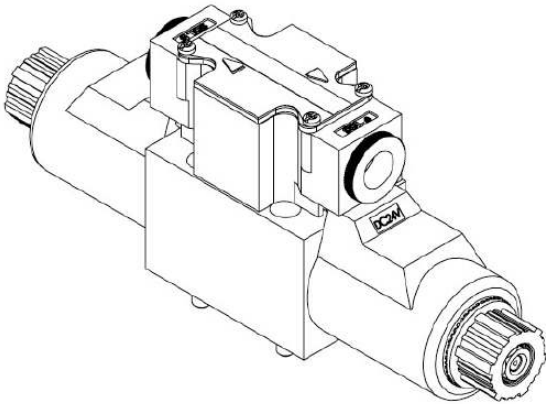

Solenoid Valve Assembly (947167)

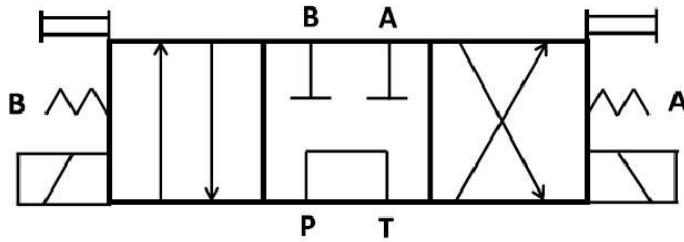

Hydraulic Symbol (947167)

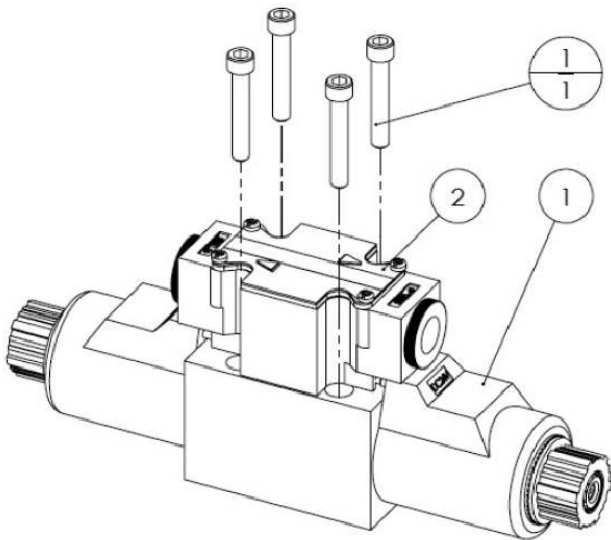

Solenoid Valve Assy Parts List (947167)

- 1. Solenoid valve, x1 (947168)**
- 1-1 Bolt x4 (947170)**
- 2 Cover Plate, x1 (947169)**

DEXRON® III OIL SAFETY DATA

FIRST AID MEASURES

Eye: No specific first aid measures are required. As a precaution, remove contact lenses, if worn, and flush eyes with water.

Skin: No specific first aid measures are required. As a precaution, remove clothing and shoes if contaminated. To remove the material from skin, use soap and water. Discard contaminated clothing and shoes or thoroughly clean before reuse.

Ingestion: No specific first aid measures are required. Do not induce vomiting. As a precaution, get medical advice.

Inhalation: No specific first aid measures are required. If exposed to excessive levels of material in the air, move the exposed person to fresh air. Get medical attention if coughing or respiratory discomfort occurs.

Note to Physicians: In an accident involving high-pressure equipment, this product may be injected under the skin. Such an accident may result in a small, sometimes bloodless, puncture wound. However, because of its driving force, material injected into a fingertip can be deposited into the palm of the hand. Within 24 hours, there is usually a great deal of swelling, discoloration, and intense throbbing pain. Immediate treatment at a surgical emergency center is recommended.

FIRE

Leaks/ruptures in high pressure system using materials of this type can create a fire hazard when in the vicinity of ignition sources (e.g. open flame, pilot lights, sparks, or electric arcs).

FLAMMABLE PROPERTIES:

Flashpoint: (Cleveland Open Cup) 178 °C (352 °F) Minimum

EXTINGUISHING MEDIA: Use water fog, foam, dry chemical or carbon dioxide (CO₂) to extinguish flames.

PROTECTION OF FIRE FIGHTERS:

Fire Fighting Instructions: This material will burn although it is not easily ignited. See Section 7 for proper handling and storage. For fires involving this material, do not enter any enclosed or confined fire space without proper protective equipment, including self-contained breathing apparatus.

Combustion Products: Highly dependent on combustion conditions. A complex mixture of airborne solids, liquids, and gases including carbon monoxide, carbon dioxide, and unidentified organic compounds will be evolved when this material undergoes combustion.

ACCIDENTAL RELEASE MEASURES

Protective Measures: Eliminate all sources of ignition in vicinity of spilled material.

Spill Management: Stop the source of the release if you can do it without risk. Contain release to prevent further contamination of soil, surface water or groundwater. Clean up spill as soon as possible. Use appropriate techniques such as applying non-combustible absorbent materials or pumping. Where feasible and appropriate, remove contaminated soil. Place contaminated materials in disposable containers and dispose of in a manner consistent with applicable regulations.

ECOLOGICAL INFORMATION

Waste disposal: In accordance with all environmental regulations applicable to your area.

Spillage: Prevent entry into drains, sewers and water course. Soak up with diatomaceous earth or other inert material. Store in appropriate container for disposal.

Ecotoxicity: This material is expected to be harmful to aquatic organisms and may cause long-term adverse effects in the aquatic environment. The ecotoxicity hazard is based on an evaluation of data for the components or a similar material.

HANDLING

Precautionary Measures: DO NOT USE IN HIGH PRESSURE SYSTEMS in the vicinity of flames, sparks and hot surfaces. Use only in well ventilated areas. Keep container closed. Keep out of the reach of children.

General Handling Information: Avoid contaminating soil or releasing this material into sewage and drainage systems and bodies of water.

Static Hazard: Electrostatic charge may accumulate and create a hazardous condition when handling this material. To minimize this hazard, bonding and grounding may be necessary but may not, by themselves, be sufficient. Review all operations which have the potential of generating and accumulating an electrostatic charge and/or a flammable atmosphere (including tank and container filling, splash filling, tank cleaning, sampling, gauging, switch loading, filtering, mixing, agitation, and vacuum truck operations) and use appropriate mitigating procedures.

DISPOSAL CONSIDERATIONS

Use material for its intended purpose or recycle if possible. Oil collection services are available for used oil recycling or disposal. Place contaminated materials in containers and dispose of in a manner consistent with applicable regulations.

GB947/GB947-220 ACCESSORIES

*Approved for use on Gage Bilt CE installation tools and/or other manufacturer's CE approved tools of similar design.
(Sold Separately)*



GB947 & GB947-220 Powerunit Kits:

The GB947 (115 volt single phase, alternating current) Powerunit is available in various kits to suit your particular need. The kits include the GB947 Powerunit, control cord, hoses, hydraulic couplers and electrical connector for attaching the installation equipment.

The GB947-12 Kit includes the GB947 Powerunit and a 12-foot hose kit, part # 940701

The GB947-26 Kit includes the GB947 Powerunit and a 26-foot hose kit, part # 940705

The GB947-38 Kit includes the GB947 Powerunit and a 38-foot hose kit, part # 940709

The GB947-52 Kit Includes the GB947 Powerunit and a 52-foot hose kit, part # 940714

The GB947-220 (230 volt, single phase, alternating current) Powerunit is available in various kits to suit your particular need. The kits include the GB947-220 Powerunit, control cord, hoses, hydraulic couplers and electrical connector for attaching the installation equipment.

The GB947-220-12 Kit includes the GB947 Powerunit and a 12-foot hose kit, part # 940701

The GB947-220-26 Kit includes the GB947 Powerunit and a 26-foot hose kit, part # 940705

The GB947-220-38 Kit includes the GB947 Powerunit and a 38-foot hose kit, part # 940709

The GB947-220-52 Kit Includes the GB947 Powerunit and a 52-foot hose kit, part # 940714

GB910 POWERUNIT



The GB910 Hydraulic Powerunit is a portable power source designed to operate a wide range of hydraulic installation tools. The unit is air powered, air actuated and delivers up to 10,000 psi (689.5 bar) working pressure.

The GB910 Hydraulic Powerunit is available separately or in kits including hydraulic quick-disconnect couplers, air connectors, air lines and hydraulic hoses in various lengths.

GB910-12: GB910 and pt.# 910701 (12 ft.) Hose Kit-Air

GB910-26: GB910 and pt.# 910705 (26 ft.) Hose Kit-Air

GB910-38: GB910 and pt.# 910709 (38 ft.) Hose Kit-Air

GB910-52: GB910 and pt.# 910714 (52 ft.) Hose Kit-Air,

Images may not reflect actual tools

GB947/GB947-220 ACCESSORIES

Approved for use on Gage Bilt CE installation tools and/or other manufacturer's CE approved tools of similar design.
(Sold Separately)



GB912

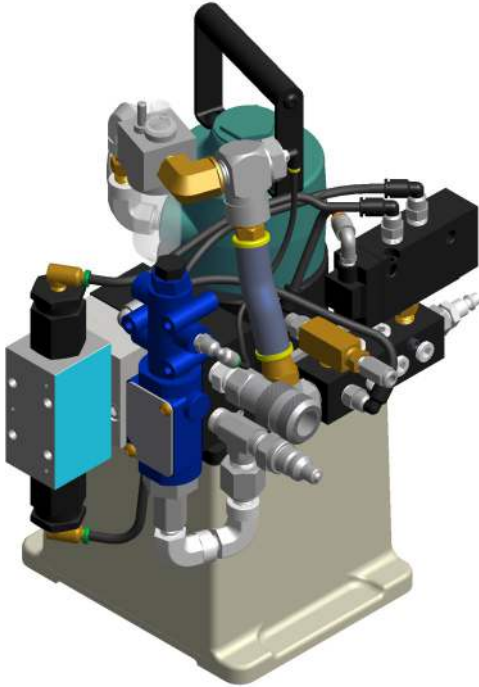

GB912-D

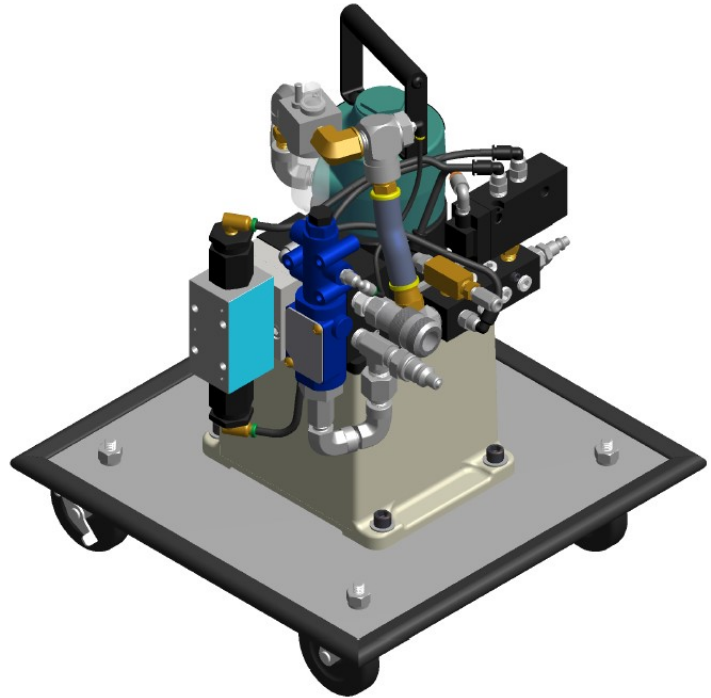

The GB912 Hydraulic Powerunit is a light-weight, portable power source designed to operate on a wide range of hydraulic installation tools. The unit is electrically powered and delivers up to 10,000 psi (689.5 bar) working pressure with simple adjustable hydraulic outputs.

The GB912 Hydraulic Powerunit is available separately or in kits including hydraulic quick-disconnect couplers, electrical connectors and hose cord kits in various lengths.

- GB912-12: GB912 and pt.# 910701 (12 ft.) Hose Kit
- GB912-26: GB912 and pt.# 910705 (26 ft.) Hose Kit
- GB912-38: GB912 and pt.# 910709 (38 ft.) Hose Kit
- GB912-52: GB912 and pt.# 910714 (52 ft.) Hose Kit

Images may not reflect actual tools



This page intentionally left blank

Hydraulic Powerunits



Approved for use on Gage Bilt CE installation tools and/or other manufacturer's CE approved tools of similar design.
(Sold Separately)

Compatible with Gage Bilt and Huck® Air/hydraulic installation tools

GB808
POWERUNIT
(Sold Separately)

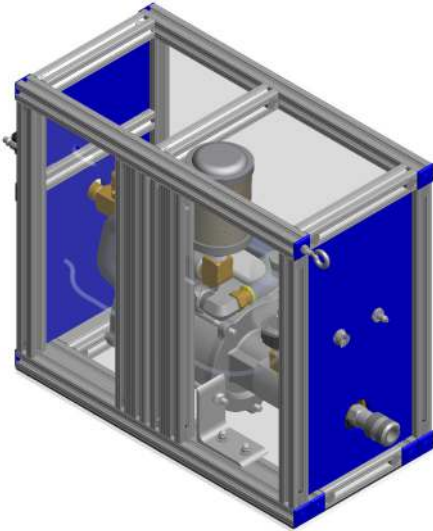

Hose Kits available to 26 ft (7.92 m)
Pressure 4,000 lbs. (177.93kN) @ 90 PSI (6.2 bar)
Fast Acting Cylinder
Requires 1/2" (12.7 mm) Air Hose
POWER: 80 - 100 PSI compressed air (5.2 - 6.9 bar)
GB808 Dimensions & weight shown below.
For all other models dimensions & weights contact Gage Bilt.

WEIGHT: 40 lbs (18.1)
HEIGHT: 16.5" (419.1 mm)
WIDTH: 9.0" (228.6 mm)
LENGTH: 24" (609.6 mm)

GB808V
POWERUNIT WITH VACUUM
(Sold Separately)

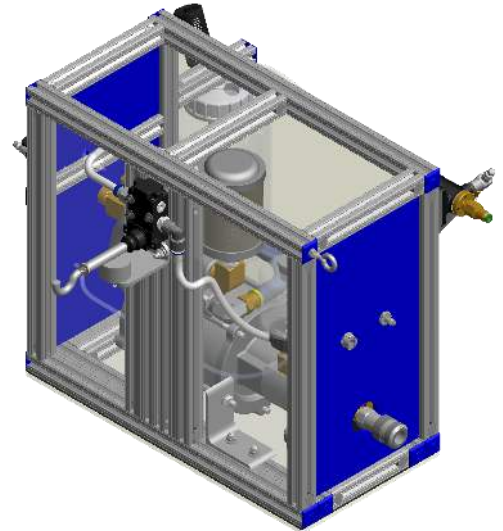

*GB808 WHEELS OPTIONAL

GB808HVB
HANGING POWERUNIT WITH VACUUM
(Sold Separately)

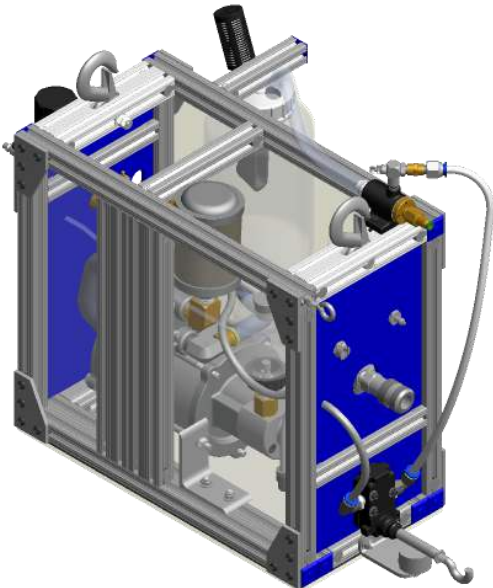

GB808HVB-100
HANGING POWERUNIT WITH VACUUM
& PINTAIL SENSOR
(Sold Separately)

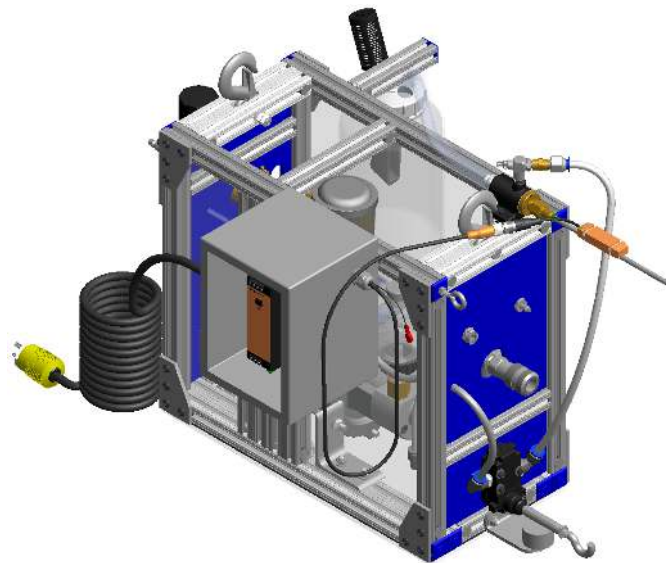

Images may not reflect actual tool